



**Bansilal Ramnath Agarwal Charitable Trust's**  
**Vishwakarma Institute of Technology**  
*(An Autonomous Institute affiliated to Savitribai Phule Pune University)*

**Structure & Syllabus of**  
**Department of Engineering, Sciences &**  
**Humanities (DESH)**

**Pattern 'A-17'**  
**F. Y. B. Tech. (ECIT Group)**  
**Effective from Academic Year 2017-18**

**Prepared by: - Board of Studies in Engineering, Sciences & Humanities**

**Approved by: - Academic Board, Vishwakarma Institute of Technology, Pune**

**Signed by,**

**Chairman – BOS**

**Chairman – Academic Board**

## Content

Sr. No.	Title	Page No.
	<b>Program Outcomes</b>	3
	<b>Course Structure – Core Module and Interdisciplinary Module</b>	4
	<b>Course Syllabi for courses - Core Module</b>	
1	THL CS101THL Computer Programming	6
2	THL ES103THL Electrical Engineering	8
3	TH ES101TH Calculus	10
4	TH ES102TH Linear Algebra	12
5	TH EC101TH Electronics Engineering	14
6	TH ES106TH Biomedical Technology	16
7	TH HS151TH Indian Philosophy and Ethics	18
8	L EC101L Hardware & Software Workshop	20
	<b>Course Syllabi for courses – Interdisciplinary Module</b>	
9	THL ES104THL Applied Physics	22
10	TH ME103TH Engineering Foundations	26
11	TH ES107TH Engineering Mechanics	28
	THL ME101THL Engineering Drawing	30
	TH HS152TH Behavioral Sciences	32
	TH HS102TH German	33
	TH HS105TH French	35
	TH HS103TH Japanese	36
	TH HS106TH Chinese	38
	TH HS104TH Sanskrit	39
	L HS153L Soft Skills and Seminar	40
	<b>Courses to be offered in Semester I only</b>	
	AU HS157AU Fundamental Mathematics	41
	AU HS101AU English	42
	AU HS155AU Environmental Science	44
	<b>General Proficiency Courses</b>	
	L GP101L Aerobics	46
	L GP102L Bharatnatyam	47
	L GP103L Chess	48
	L GP104L Drawing and Painting	49
	L GP105L Flute	50
	L GP106L Guitar	51
	L GP108L Photography	52
	L GP109L Tabla	53
	L GP110L Taekwondo	54
	L GP111L Vocal	55
	L GP112L Yoga and Pranayam	56
	L GP115L Film Appreciation	57
	L GP122L Violin	58
	L GP123L Health Awareness and Monitoring	59
	<b>Academic Information – Please visit <a href="http://www.vit.edu">www.vit.edu</a></b>	

## **Program Outcomes**

- 1. Engineering knowledge:** Apply the knowledge of mathematics, science, engineering fundamentals, and an engineering specialization to the solution of complex engineering problems.
- 2. Problem analysis:** Identify, formulate, review research literature, and analyze complex engineering problems reaching substantiated conclusions using first principles of mathematics, natural sciences, and engineering sciences.
- 3. Design/development of solutions:** Design solutions for complex engineering problems and design system components or processes that meet the specified needs with appropriate consideration for the public health and safety, and the cultural, societal, and environmental considerations.
- 4. Conduct investigations of complex problems:** Use research-based knowledge and research methods including design of experiments, analysis and interpretation of data, and synthesis of the information to provide valid conclusions.
- 5. Modern tool usage:** Create, select, and apply appropriate techniques, resources, and modern engineering and IT tools including prediction and modeling to complex engineering activities with an understanding of the limitations.
- 6. The engineer and society:** Apply reasoning informed by the contextual knowledge to assess societal, health, safety, legal and cultural issues and the consequent responsibilities relevant to the professional engineering practice.
- 7. Environment and sustainability:** Understand the impact of the professional engineering solutions in societal and environmental contexts, and demonstrate the knowledge of, and need for sustainable development.
- 8. Ethics:** Apply ethical principles and commit to professional ethics and responsibilities and norms of the engineering practice.
- 9. Individual and team work:** Function effectively as an individual, and as a member or leader in diverse teams, and in multidisciplinary settings.
- 10. Communication:** Communicate effectively on complex engineering activities with the engineering community and with society at large, such as, being able to comprehend and write effective reports and design documentation, make effective presentations, and give and receive clear instructions.
- 11. Project management and finance:** Demonstrate knowledge and understanding of the engineering and management principles and apply these to one's own work, as a member and leader in a team, to manage projects and in multidisciplinary environments.
- 12. Life-long learning:** Recognize the need for, and have the preparation and ability to engage in independent and life-long learning in the broadest context of technological change.

**F.Y. B. Tech. Structure for ECIT Group: Core Module Semester I and Semester II**

FF No. 653

Course Code	Course Type	Course Name	Teaching Learning Scheme					Assessment Scheme (100 mark scale)				
			Th	Lab	Project	Hrs. / Week	Credits	ISA (100 marks converted to 30 in case of THL and TH courses)			MSE (100 marks converted to 35) Unit 1-3	ESE (100 marks converted to 35) Unit 4-6
								CA	MSE	ESE		
<b>Common for Semester I and Semester II (Note: * - Only in Semester I and # - Only in Semester II : for all ECIT and MCIP Students)</b>												
CS101THL	THL	Computer Programming	3	2	2	7	5	30	35	35	100	100
ES103THL	THL	Electrical Engineering	3	2	0	5	4	30	35	35	100	100
ES101TH / ES102TH	TH	Calculus*/ Linear Algebra#	3	0	0	3	3	30	35	35	100	100
EC101TH	TH	Electronics Engineering	3	0	0	3	3	30	35	35	100	100
ES106TH	TH	Biomedical Technology	2	0	0	2	2	30	35	35	100	100
HS151TH	TH	Indian Philosophy and Ethics	2	0	0	2	2	30	35	35	--	--
EC101L	L	Hardware and Software Workshop	0	2	0	2	1	30	35	35	--	--
GP1XXL	L	General Proficiency	0	2	0	2	1	30	35	35		
<b>Common Total</b>			<b>16</b>	<b>8</b>	<b>2</b>	<b>26</b>	<b>21</b>	--	--	--	--	--
<b>Courses to be offered in Semester I only</b>												
ES157AU	AU	Fundamental Mathematics	2	0	0	2	0	30	35	35	--	--
HS101AU	AU	English						30	35	35		
HS155AU	AU	Environmental Science						30	35	35	--	--
<b>Grand Total (Semester I)</b>			<b>18</b>	<b>8</b>	<b>2</b>	<b>28</b>	<b>21</b>	--	--	--	--	--
<b>Courses to be offered in Semester II only</b>												
ES108L	L	Mini Project	0	0	4	4	2	30	35	35	--	--
<b>Grand Total (Semester II)</b>			<b>16</b>	<b>8</b>	<b>6</b>	<b>30</b>	<b>23</b>	--	--	--	--	--

**F.Y. B. Tech. Structure for ECIT Group : Interdisciplinary Module Semester I and Semester II**

FF No. 653

Course Code	Course Type	Course Name	Teaching Learning Scheme					Assessment Scheme (100 mark scale)					
			Th	Lab	Project	Hrs. / Week	Credits	ISA (100 marks converted to 30 in case of THL and TH courses)			MSE (100 marks converted to 35) Unit 1-3	ESE (100 marks converted to 35) Unit 4-6	
								CA	MSE	ESE			
<b>Common for Semester I and Semester II (Note: * - Only in Semester I and # - Only in Semester II : for all ECIT and MCIP Students)</b>													
ES104THL	THL	Applied Physics	3	2	0	5	4	30	35	35	100	100	
ES101TH / ES102TH	TH	Calculus*/ Linear Algebra#	3	0	0	3	3	30	35	35	100	100	
ME103TH	TH	Engineering Foundations	3	0	0	3	3	30	35	35	100	100	
ES107TH	TH	Engineering Mechanics	3	0	0	3	3	30	35	35	100	100	
ME101THL	THL	Engineering Drawing	2	2	0	4	3	30	35	35	100	100	
HS152TH	TH	Behavioral Sciences	2	0	0	2	2	30	35	35	--	--	
HS1XXTH	TH	International Language	2	0	0	2	2	30	35	35	--	--	
HS153L	L	Soft Skills and Seminar	0	2	0	2	1	30	35	35			
<b>Common Total</b>			<b>18</b>	<b>6</b>	<b>0</b>	<b>24</b>	<b>21</b>	--	--	--	--	--	
<b>Courses to be offered in Semester I only</b>													
ES157AU	AU	Fundamental Mathematics	2	0	0	2	0	30	35	35	--	--	
HS101AU	AU	English						30	35	35			
HS155AU	AU	Environmental Science						30	35	35	--	--	
<b>Grand Total (Semester I)</b>			<b>20</b>	<b>6</b>	<b>0</b>	<b>26</b>	<b>21</b>	--	--	--	--	--	
<b>Courses to be offered in Semester II only</b>													
ES108L	L	Mini Project	0	0	4	4	2	30	35	35	--	--	
<b>Grand Total (Semester II)</b>			<b>18</b>	<b>6</b>	<b>4</b>	<b>28</b>	<b>23</b>	--	--	--	--	--	

**Course Name: Computer Programming**

**Course Code: CS101THL**

**Course Type: THL**

**Credits: 5**

**Teaching Scheme:** Theory : 3 Hours / Week  
Lab. : 2 Hours / Week  
Project Lab : 2 Hours / Week

**Unit 1: Introduction to programming (6 Hours)**

Problem solving using computers; algorithms and flowcharts; using simple cpp graphics commands; notion of syntax and semantics; Repeating a block of commands; Nested repeat; numerical functions; comments; Data types; identifiers; initialization; const; Input and Output; Arithmetic operators; programming idioms; Compound assignment; blocks; scope and shadowing.

**Unit 2: Flow of Control (7 Hours)**

**Conditional Constructs:** Relational and Logical Operators, various forms of if..else statements, ternary operator, switch..case statement;

**Loops:** Types of Loops, while, do..while, for, break and continue, goto statement.

**Unit 3: Array, Strings and Pointers (7 Hours)**

**Arrays:** Definition, syntax, element operations, memory representation, initialization. Two dimensional array, row and column major;

**Applications of arrays:** sorting, searching and matrix operations;

**Strings:** Introduction, Array of characters, output, input, character string constant, Accepting multiword string, Array of strings.

**Unit 4: Pointers, Functions and Recursion (10 Hours)**

**Pointers:** Definition, syntax, address of operator, pointer variables, relevance of data type in pointer variables, dereferencing operator, Pointer to pointer, address arithmetic; Accessing array elements using pointers

**Functions:** Introduction; definition; anatomy of function; execution of function; Scope of various types of variable; scope; local and global variables; nested function call; returning values from function; Menu driven programs;

**Function and Pointers:** Call by value v/s call by address, Passing array to function, returning pointers from function, dangling pointers;

**Function and strings:** Library functions from string.h library, building user defined functions for string operations;

**Recursive Function:** Definition, Examples, Types of recursion.

**Unit 5: Structures (6 Hours)**

**Structure:** Need, Definition, syntax, declaration and initialization, structure variables, accessing and assigning values to structure variables, “dot” operator;

**Applications of structure:** Functions and structures, array and structure, structure within a structure, pointers and structures.

**Unit 6: File handling (4 Hours)**

Introduction to file handling, using file pointers, file opening modes, reading from file, writing into file, closing file, fscanf, fprintf, fread, fwrite, fseek, ftell, rewind.

**List of Practical:**

Sr. No.	Topic
1	Graphics: Drawing basic diagrams using SimpleCpp
2	Making computer calculate stuff : calculating average, finding roots of quadratic equation, complex numbers etc.
3	Switch statement: controlling the turtle
4	Loops, Conditionals and Arithmetic operations: Converting base of a number, Generating arithmetic and geometric progressions, Buttons on Canvas, Reversing n digit number etc.
5	Example: marks display program, find min/max Generate roll numbers
6	Linear and Binary Search
7	Bubble sort
8	Insertion and Selection Sort
9	Matrix arithmetic
10	Demonstrating pointer to pointer, pointer arithmetic
11	Assignment on functions – menu driven programs, etc.
12	Using library functions
13	Implementing User defined string functions
14	Calculate factorial, generating progressions, GCD, LCM using recursion
15	Create Structures for: student result, employee payroll, library book issuing
16	File handling: Store employee records in a file

**Text Books:**

1. *An Introduction to Programming through C++*, AbhiramRanade, Mc Graw Hill Education. ISBN 978-9-33-290151-3
2. *Let us C*, Y. Kanetkar, Second Edition, BPB Publication. ISBN: 8176566217.

**Reference Books:**

1. *Programming language – ANSI C*, Brian W Kernighan and Dennis Ritchie, Second edition ISBN 0-13-110370-9
2. *Programming with C- Schaum's outline Series*, B. Gottfried, Second edition, Tata McGraw Hill Publication, ISBN 0-07-463491-7
3. *C By Example*, Kalicharan Noel, UK, Cambridge University Press
4. *C How to Program*, Deitel H N, Deitel P J, third edition, New Delhi, Prentice Hall of India, 2002
5. *A first book of C- Fundamental of C Programming*, Gary Bronson and Stephen Menconi, ISBN: 0314073361,

**Course Outcomes:**

Upon completion of the course, graduates will be able to –

1. Apply programming fundamentals to construct concise solutions.
2. Demonstrate available algorithmic principles to generate efficient solutions.
3. Justify modular programming approach by making use of elementary as well as superior data structures.
4. Implement programming constructs to solve real world problems.
5. Construct derived data type for real world entities.
6. Apply file handling for permanent storage of data.

**Course Name: Electrical Engineering**

**Course Code: ES103THL**

**Course Type: THL**

**Credits: 4**

**Teaching Scheme: Theory : 03 Hours / Week**

**Lab/Project : 02Hours / Week**

**Unit 1: DC circuits**

**(7 Hours)**

Ohms law, Kirchhoff's laws, Source transformation, and Network reduction using series- parallel and Star-Delta transformations, Superposition theorem, Thevenin's theorem, Norton's theorem, Maximum power transfer theorem. Numerical based on above.

**Unit 2: AC Circuits 1**

**(7 Hours)**

AC fundamentals – standard expression of AC quantity, Average value, RMS value, Peak factor, Form factor, concept of phasor, R-L-C series circuits, Concept of active, reactive and apparent power, power factor. Numericals based on above.

**Unit 3: AC Circuits 2**

**(6 Hours)**

AC parallel circuits, Three Phase balanced AC circuits, phase sequence, concept of line and phase values of Star-Delta connections. Concept of Neutral, Earth. Numericals based on above.

**Unit 4: Transformers**

**(6 Hours)**

Construction, working principle, emf equation of single phase transformer, transformation ratio, concept of ideal and practical transformer. constant flux operation, equivalent circuit, losses, regulation, efficiency at various loads. Numericals based on above.

**Unit 5: DC Motors**

**(7 Hours)**

Construction, working principle, emf equation, types, concept of back emf, torque equations, motor characteristics, different starters, Numericals based on above. C.T. and P.T, ferrite core transformer.

**Unit 6: Induction Motors**

**(7 Hours)**

Three phase induction motor, classification, construction, RMF, working principle, standstill and running condition, torque equation, T-s characteristic, maximum torque, slip ring and squirrel cage type, starters, applications. Numericals based on above.

**List of Practicals:**

1. Load test on 1 phase transformers.
2. Load test on d.c. shunt motor.
3. Numerical practice on Unit 1
4. Speed control of d.c. shunt motor.
5. Three phase star and delta circuit.
6. Numerical practice on Unit 2
7. Load test on three phase induction motor.
8. Numerical practice on Unit 3,4
9. 9.(A)Study -of A.C. motor starter



- 9.(B) Study-Introduction to electrical component.
- 9.(C) Study-Lab Assignment : Electrical bill study
- 9.(D) Study-Substation visit.
- 9.(E) Study of D.C. motor starter.
- 10. Numerical practice on Unit 5,6

**Text Books:**

- 1. *Electrical Technology-Edward Hughes.*
- 2. *Electrical Technology- B.L.Theraja Vol-2.*
- 3. *Electrical Technology –H.Cotton.*

**Reference Books:**

- 1. *Electric Machinery, TMH(Sixth Edition)-Fitzgerald.*
- 2. *Electrical Machines, Drive and power system, Pearson education-Theodore Wildi.*
- 3. *Kothari D. P and Nagrath IJ, “Basic Electrical Engineering”, Second edition, Tata McGraw - Hill, 2009.*
- 4. *Electrical Machines and transformers- Irving Kosow.*
- 5. *V.K.Metha, Rohit Metha, “Basic Electrical Engineering”, Fifth edition, S.Chand & Co, 2012.*

**Course Outcomes:**

The student will be able to –

- 1. Understand different theorems and able to solve numerical on it.
- 2. Understand concept of single phase and three phase a.c. circuit.
- 3. Understand AC circuit three phase circuits.
- 4. Find regulation and efficiency of single phase transformer.
- 5. Understand construction and working of DC machines and solve numerical problems.
- 6. Understand construction and working of induction motor and the T-S characteristic.

**Course Name: Calculus**

**Course Code: ES101TH**

**Course Type: TH**

**Credits: 3**

**Teaching Scheme: Theory : 03 Hours / Week**

**Unit 1: Functions of single variable**

**(6 Hours)**

Expansions of functions: Taylor's & Maclaurin's series, Curves (Cartesian, Polar and parametric standard curves) in 2D.

**Unit 2: Functions of two or more variables**

**(8 Hours)**

Introduction to functions of two or more variables, Level surfaces, limits and continuity, Partial derivatives, chain rules, derivative of implicit function. Homogeneous functions, Euler's theorem, Jacobian, maxima and minima of functions of two variables, Method of Lagrange's multipliers.

**Unit 3: Double Integration**

**(6 Hours)**

Beta and Gamma function, Introduction to Cartesian and polar curves, Evaluation of double integrals, change of order.

**Unit 4: Triple Integration**

**(8 Hours)**

Evaluation of double integral using Jacobian transformation, Co-ordinate systems in 3 Dimensions, Standard surfaces, Evaluation of triple integrals, Dirichlet's integral, change of variables

**Unit 5: Vector Differentiation**

**(6 Hours)**

Scalar and Vector point functions, tangential and normal components of velocity and acceleration, gradient, directional derivative, divergence and curl.

**Unit 6: Vector Integration**

**(6 Hours)**

Line integral, work done, conservative vector field, Surface integral, Theorem of Green, Stokes and Gauss.

**Text Books:**

1. *Thomas G. B. and Finney, 'Calculus and analytic Geometry', 11<sup>th</sup> Edition, Pearson Publications*
2. *Ron Larson and Bruce H. Edwards, 'Text book of Calculus', Brooke/Cole, a part of Cengage Learning ( Indian Edition), (c) 2011.*

**Reference Books:**

1. *Murray R. Spiegel, 'Advanced Calculus', Schaum's out line series, New Delhi, 1st Edition, 1981, McGraw Hill International Book Co.*
2. *Tom Apostol, 'Calculus', volume-II, 2<sup>nd</sup> Edition, Wiley India Edition*
3. *Erwin Kreyszig, 'Advanced Engineering Mathematics' 10<sup>th</sup> Edition, Dec. 2010, , John Wiley and sons, Inc*

**Course Outcomes:**

The student will be able to –

1. Acquire the knowledge of Taylor series, partial derivatives, multiple integral, Beta and Gamma function, curve tracing, vector differentiation, vector integration

2. Use properties of functions of several variables, beta and gamma functions, partial derivative, use of Jacobian transformation
3. Demonstrate the knowledge of chain rules, implicit functions and change of order of integration
4. Recognize and identify curves and surfaces, homogeneous functions, change of variables in triple integral, problems on Gauss divergence theorem, problems on Stoke's theorem.
5. Interpret the properties of vector differentiation and integration
6. Apply the knowledge of series expansions of functions, partial derivative, multiple integral, vector differentiation and integration

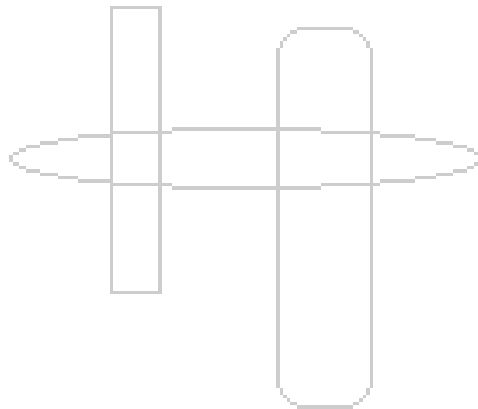

**Course Name: Linear Algebra**

**Course Code: ES102TH**

**Course Type: TH**

**Credits: 3**

**Teaching Scheme: Theory : 03 Hours / Week**

**Unit 1: System of Linear Equations (7 Hours)**

Rank of matrix, Elementary Matrices, System of linear equations, Gauss-Jordan Elimination. Applications of System of Linear equations.

**Unit 2. Vector Spaces (7 Hours)**

Euclidean Vector space, Vector Space, Subspace, Span of a set, Spanning Set, Fundamental Subspaces, Linear Dependence, Independence, Basis and dimension of a vector space.

**Unit 3. Inner Product of Vector Spaces (7 Hours)**

Inner product Spaces, Orthogonal Bases: Gram Schmidt Process, Mathematical Models and Least Squares Analysis.

**Unit 4. Linear Transformations (7 Hours)**

Introduction to linear transformations, Matrices for Linear Transformation, Orthogonal Transformation, Geometric properties of linear operators on  $\mathbb{R}^2$  and  $\mathbb{R}^3$ .

**Unit 5. Eigen Values and Eigen Vectors (7 Hours)**

Eigen Values and Eigen Vectors of a matrix, Diagonalization, Symmetric Matrices and Orthogonal Diagonalization, Quadratic forms and its Applications.

**Unit 6. Complex Numbers (7 Hours)**

Complex numbers and its Various forms, Geometrical Meaning of complex numbers, De Moivre's Theorem, Roots of the complex numbers, Introduction to functions of complex variable: Circular and Hyperbolic Functions, Logarithm functions, Separation of real and imaginary parts.

**Text Books:**

1. Ron Larson and David C. Falvo, 'Linear Algebra An Introduction', 1<sup>st</sup> Edition, Cengage Learning ( Indian Edition).
2. B.V.Ramana, 'Higher Engineering Mathematics' Tata McGraw-Hill publishing co. Ltd.

**Reference Books:**

1. David C. Lay, 'Linear Algebra and its Applications', 3<sup>rd</sup> Edition, Pearson.
2. Gilbert Strang, 'Linear Algebra and its Applications', 4<sup>th</sup> Edition, Cengage Learning.
3. Erwin Kreyszig, 'Advanced Engineering Mathematics' 10<sup>th</sup> Edition, Dec. 2010, , John Wiley and sons, Inc

**Course Outcomes:**

The student will be able to –

1. Acquire the concepts of linear algebra and Complex numbers
2. Relate matrices to linear transformations and interpret geometrically
3. Demonstrate the knowledge of linear dependence/independence, Basis and Dimension, hyperbolic functions.

4. Recognize the concepts of spanning set, basis, dimension linear transformation, inner product, orthogonal transformation
5. Set up and solve system of linear equations, orthogonal basis using Gram-Schmidt Process.
6. Apply the knowledge to solve problems on least square, Quadratic forms, roots of the polynomial equations.

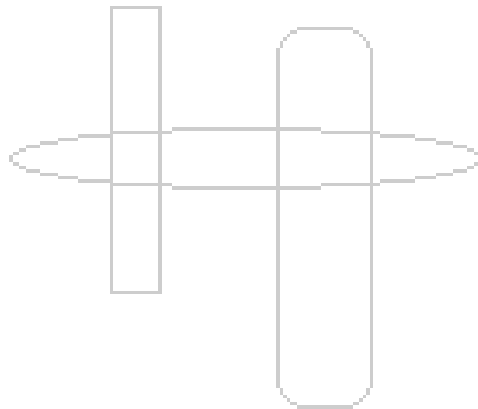

**Course Name: Electronics Engineering**

**Course Code: EC101TH**

**Course Type: TH**

**Credits: 3**

**Teaching Scheme: Theory : 03 Hours / Week**

**Unit 1: Semiconductor Devices**

**(7 Hours)**

Diode, Zener diode, BJT, FET–Symbol, Structure, Characteristics and Types

**Unit 2: Digital Electronics**

**(7 Hours)**

Boolean algebra, De-Morgan's Theorem, Concepts of K-Maps; Logic gates and Truth table, NAND and NOR gate as universal gate

**Unit 3: Integrated Circuits**

**(7 Hours)**

Concept of IC; Types of ICs, Package type of ICs, Basics of Op-Amp, Open loop Op–Amp configurations, 555 timer IC.

**Unit 4: Analog Communication**

**(7 Hours)**

Communication system, Need for modulation, Types of modulation–AM, FM and PM;AM – basic circuit, waveforms, spectrum, bandwidth, Receiver block diagram

**Unit 5: Filters**

**(7 Hours)**

Concept of Filters, Classification of filters– Passive and Active, AF and RF, Analog and Digital; Circuits for Passive filters; Active filters–Butterworth and Chebyshev, Concept of  $N^{\text{th}}$  order filter

**Unit 6: Applications of Electronic Circuits**

**(7 Hours)**

Applications of diode as regulator and rectifier; Application of Transistor as an amplifier; Registers and Counters; Digital Adder Circuits, Applications of Op-Amp–comparator, log amplifier, V-I and I-V converters, Integrator, Differentiator; Modulator Circuits; Study of Datasheet

**Text Books:**

1. *Electronic Devices, Thomas L. Floyd, Pearson Education.*
2. *M. Morris Mano, Digital Design - 3<sup>rd</sup> Edition, Pearson Education.*
3. *Op-amp and Linear Integrated Circuits by Ramakant A. Gayakwad, Prentice-Hall of India pvt.ltd.*
4. *Analog Communication by Louis E. Frenzel, Tata Mc Graw Hill Education pvt.ltd.*

**Reference Books:**

1. *Electronic Circuits, Analysis and Design by Donald A. Neamen, Tata-Mc Graw Hill Education pvt.ltd.*
2. *Modern Digital Electronics by R.P. Jain, Tata-Mc Graw Hill Education pvt.ltd*
3. *Electronics Devices and Circuits by J.B. Gupta, S.K. Kataria and Sons Publishing Company.*
4. *Digital Logic: Applications and Design, John M. Yarbrough West Publishing Company, 1997 Technology and Engineering.*

**Course Outcomes:**

The student will be able to –

1. Explain the basic concepts and working of electronic devices like diode, BJT and FET.
2. Illustrate digital circuits using logic gates.

3. Elaborate open loop configurations of integrated circuits.
4. Describe the need of analog modulation techniques.
5. Compare the frequency response of active and passive filters.
6. Discuss the applications of electronic circuits.

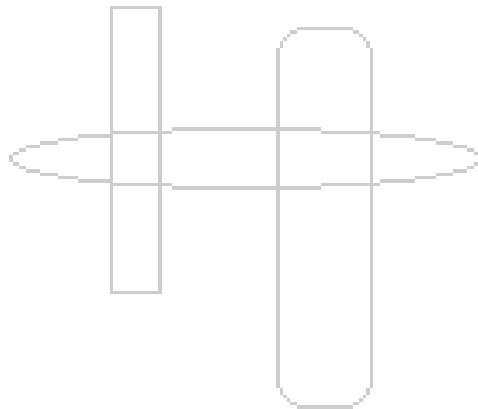

**Course Name: Biomedical Technology**

**Course Code: ES106TH**

**Course Type: TH**

**Credits: 2**

**Teaching Scheme: Theory : 02 Hours / Week**

**Unit 1: Human Anatomy**

**(6 Hours)**

Composition of Blood and its Functioning, Cardiovascular System; Structure and working of Heart, Electro conduction System of Heart, Circulatory System, Nervous System; The Neuron structure, Structure and Functions of CNS (Brain and Spinal cord), PNS and ANS, Respiratory system; Organs of Respiration, Mechanism of Breathing, Regulation of Respiration (Lung Functioning)

**Unit 2: Physiological Parameters I**

**(4 Hours)**

Basic Electrode Theory, Electrode Model Circuit, Types of electrodes (Passing Reference), Body Temperature Measurement System - Thermometer, Incubator, Electroencephalograph (EEG) and its Recording, Heart related Parameters such as Electrocardiograph (ECG) and its Recording

**Unit 3 Physiological Parameters II**

**(4 Hours)**

Heart related Parameters such as Pacemaker, Blood Pressure Measurement, Pulse Rate Measurement, Pulse Oximeter, Blood Cell Counter and Spiro Meter

**Unit 4: Imaging system**

**(6 Hours)**

X-ray (Principal, Construction and Working of Equipment) and Computed Tomography (Principal, Construction and Working of Equipment), Magnetic Resonance Imaging (Principal, Construction and Working of Equipment), Ultrasonic Imaging (Principal, Construction and Working of Equipment), Positron Emission Tomography (Principal, Construction and Working of Equipment)

**Unit 5: Anthropometry and Ergonomics**

**(4 Hours)**

Anthropometry and Design, Principles of Work Design; The Workplace, Principles of Work Design; Machines and Equipment, Work related Musculoskeletal Disorders, Patient safety

**Unit 6: Health Hazards**

**(4 Hours)**

Effect of Air pollution on Lung and Eye System, Effect of Water Pollution on Gastrointestinal Track, Effect of Mobile Radiation on Brain, Effect of Noise on Ear and Brain System, Electric Shock Hazards; Causes, Symptoms and Prevention, Gross Shock, Electric Current Effect on Body (Micro and Leakage Current Shock)

**Text Books:**

1. R. S. Khandpur; *Handbook of Biomedical Instrumentation; Third Edition, TMH Publication, 2012*
2. Joseph J. Carr and John M. Brown; *Introduction to Biomedical Equipment Technology; Fourth Edition, Pearson Education, Inc. and Dorling Kindersley Publishing Inc., New Delhi, 2012*

**Reference Books:**

1. B. W. Niebel and A. Freivalds; *Methods, Standards and Work Design; Tenth Edition, WCB McGraw Hill*
2. Elaine.N. Marieb; *Essentials of Human Anatomy and Physiology; Eighth Edition, Pearson Education Inc., New Delhi*



3. *Erach Bharucha; Textbook of Environmental Studies for Undergraduate Courses; First Edition, University Press(India) Private Limited, Hyderabad, 2005*

**Course Outcomes:**

The student will be able to –

1. Understand basic functions of human body parts and working of different systems.
2. Read Electrocardiogram (ECG) and Electroencephalogram (EEG).
3. Study functioning of Pacemaker, measurement of Blood pressure, Pulse rate, Pulse oximeter, Spiro meter and Blood cell counter.
4. Understand and apply the basic tenets of fundamental technologies in X-ray, Computed Tomography, Magnetic Resonance Imaging, Ultrasonic Imaging and Positron Emission Tomography.
5. Identify and explain the principles of Anthropometry in designing work places, tools and equipments to fit the human operator.
6. Assess / predict the effect air pollution, water pollution, mobile radiation, sound and noise pollution on health.

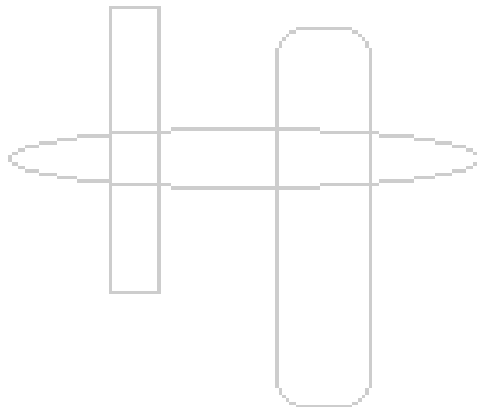

**Course Name: Indian Philosophy and Ethics**

**Course Code: HS151TH**

**Course Type: TH**

**Credits: 2**

**Teaching Scheme: Theory : 02 Hours / Week**

**Unit 1: Introduction & The Philosophy of Logic and Reasoning (Nyaya) (6 Hours)**

Introduction to “The Six Systems of Indian Philosophy of Ancient India”. The Philosophy of Logic and Reasoning (Nyaya). Sources of Valid Knowledge with their merits and de-merits. Importance of Testimony and the Logic presented to argue for the sake of a creator v/s the argument presented against one. The various objects of knowledge (Prameya)

**Unit 2: Dualism (Sankhya) and Analysis of Aspects of Reality (Vaisheshika) (6 Hours)**

The Dualistic Model, French Philosopher Rene Descartes and his ideas on Dualism, Indian system of Dualism (Sankhya) : Analogies and Validations presented for the idea of self separate from the body, Reincarnation cases, Consciousness: The mysterious missing link. The three modes of material nature and their effects on consciousness.

Analysis of aspects of Reality (Vaisheshika) : Effect of Illusion on the mind and the goal of the six systems of Indian philosophy.

**Unit 3: Self Discipline for Self Realization (Yoga sutras) (4 Hours)**

Detailed analysis of the nature of mind and the interaction of the mind and senses. The 8-fold path of Ashtanga Yoga as per Patanjali Yoga sutras and the purpose of the Yoga system.

**Unit 4: The Higher Deliberation (Uttara Mimamsa) (4 Hours)**

The Vedantic Model : The various aspects of Absolute Truth, The interaction between material nature (Prkrti) , Self (Jiva) and Absolute Self (Purusha). Comparison of the Vedantic Model with other theistic philosophies. The Bhakti Yoga model as compared to Yoga Sutras of Patanjali.

**Unit 5 : Elevation through performance of duty (Karma Mimamsa) (4 Hours)**

The Universal Law and Order (The web of Karma), Polytheistic model v/s Monotheistic model, Karma Yoga model. Universal utilities and the purpose of ritualism.

**Unit 6: Ethics from Indian Epics (4 Hours)**

Ethics related to Leadership, Cooperation, Team Spirit, Competitiveness, Wealth and Friendship from Chanakya Niti and Mahabharat.

**Text Books:**

1. *Rajiv Malhotra ,Being Different’ : An Indian Challenge to Western Universalism, Harper Collins Publishers India. ISBN No : 978-93-5116-050-2*
2. *Suhotra Dasa Tapovanachari, The Six systems of Vedic Philosophy, (Online PDF book)*

**Reference Books:**

1. *Devamrita Swami, Searching for the Vedic India, Bhaktivedanta Book Trust. ISBN 0-89213-350-3*
2. *Patita Pavan , Sri Chanakya Niti: Ancient Sense for Modern Success, ISBN 978-93-82109-25-9. Abhay Ashram Publishing.*
3. *Govinda das, Voice your choice: Ethics from Epics, White Woods Publishing House. ISBN : 978-93-81-283042*
4. *Hornyanzky, Istvan Tasi. Nature’s IQ Balazs Torchlight Publishing ISB: 978-0-9817273-0-1.*

**Course Outcomes:**

The student will be able to –

1. Apply the most appropriate tool of acquiring knowledge for a suitable object of knowledge.
2. Discern the reasons for the dual model of self & body and effects of the three modes on consciousness.
3. Evaluate the purpose of the 8 steps of the Yoga sutras and their consequence on the human mind.
4. Contrast the aspects of Absolute truth as laid out by the Vedanta model with the world's theistic philosophies.
5. Argue for the sake of Universal Law of Karma and the differences between monotheistic and polytheistic models.
6. Practice ethics in one's personal, professional and family life.

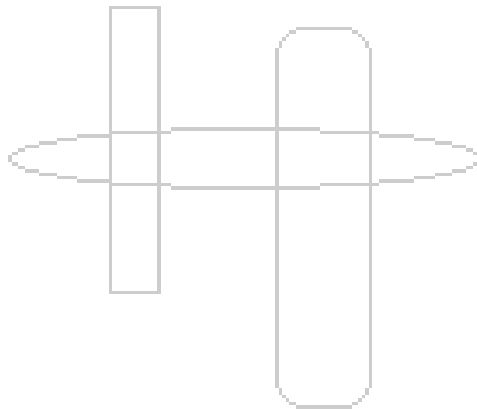

**Course Name: Hardware & Software Workshop**

**Course Type: EC101L**

**Course Type: L**

**Credits:1**

**Teaching Scheme: Lab: 2 Hours / Week**

**List of Practical:**

<b>Sr. No.</b>	<b>Topic</b>
1	<b>Installation and Configuration of Operating system</b> Operating system installation: Disk Formatting, Disk partitioning (Dual boot), Linux installation and configuration Software Installation: Device drivers, Anti-virus software
2	<b>System Administration</b> Control Panel and Admin Tools, User Account Management, Disk Defragmentation, File permissions
3	<b>Introduction to Computer Network</b> LAN setup (IP address, DNS), Basic networking commands (ipconfig, ping, etc), Accessing Remote desktop, Cable Crimping
4	<b>Circuit Testing</b> Identification of Components Bread board circuit and PCB circuit testing
5	<b>PCB Manufacturing</b> Prepare PCB from given circuit layout
6	<b>Circuit simulator</b> Single stage amplifier, Oscillator
7	<b>Sheet Metal Work</b> Introduction. Use of marking tools & hand tools such as steel rule, marker, scissors, centre punch, measuring gauge, etc. Safety precautions. Demonstration of few operations such as marking, cutting, bending etc & one job on sheet metal.
8	<b>Welding</b> Introduction. Principle of manual metal arc welding, equipment and its operation, welding electrodes, welding joints, welding symbols, Safety precautions. Demonstration & hands on experience of few operations such as filing, welding, chipping and drilling.
9	<b>Carpentry</b> Introduction, use of marking tools and hand tools such as marking gauge, try squares, steel rules, saws, jackplane, chisels, etc. Use of power tools, safety precautions. Demonstration & hands on experience of different operations such as sawing, planning, chiseling, etc.

**Text Books:**

1. *“Computer Fundamentals”, Sinha P K, Sinha Priti, fourth edition, New Delhi, BPB Publications, 2010.*
2. *“Computer Hardware and Organization”, Sloan M E, second edition, New Delhi Galgotia Publications, 1992*
3. *Bosshart, Printed Circuit Boards: Design and Technology, Tata McGraw-Hill Education, 1983.*
4. *Robert L. Boylestad , Nashelsky Electronic Devices and Circuit Theory, Pearson Education India, 1996*
5. *S.k. HajraChudhary. Elements of Workshop Technology .media Promoters and Publishers Pvt., Ltd.*
6. *K.T. Kulkarni. Introduction to Industrial Safety. K.T. Kulkarni. Pune.*

**Reference Books:**

1. *“Computer Architecture and Organization: Design Principles and Applications”, Govindarajalu B, New Delhi, Tata McGraw Hill, 2004*
2. *“Computer Networks”, Andrew Tanenbaum, third edition, Pearson Education, India, 1993*
3. *“Data Communications and Networking”, Forouzanbehrouz A, second edition, New Delhi, Tata McGraw Hill, 2000*
4. *“Electronic Devices”, Floyd Thomas L., sixth edition, New Delhi, Pearson Education, 2006*
5. *“Troubleshooting Electronic Equipments Includes Repair and Maintenance”, Khandpur R S, second edition, New Delhi, Tata McGraw Hill, 2003*
6. *Hwaiyu Geng.Manufacturing Engineering Hand Book, McGraw Hill Publishing Co. Ltd.*
7. *Lawrence E.Doyle, Manufacturing Processes and Materials for Engineering, Prentice Hall Inc.*

**Course Outcomes:**

Students will be able to

1. Understand basics of operating system and system administration
2. Study computer networking fundamentals
3. Built the circuit on PCB
4. Simulate the circuit operation on Simulation software
5. Perform few sheet metal work, welding and carpentry operations
6. Follow safety practices

**Course Name: Applied Physics**

**Course Code: ES104THL**

**Course Type: THL**

**Credits: 4**

**Teaching Scheme: Theory : 03 Hours / Week**

**Lab/project : 02 Hours / Week**

**Unit 1: Optics**

**(7 Hours)**

**Interference:** Thin film interference, Colours in thin films, Michelson's interferometer, Applications: Wavelength and thickness, Antireflection coatings, Interference filters,

**Diffraction:** Fresnel and Fraunhofer diffraction, Single slit Fraunhofer diffraction (Qualitative), diffraction grating (Qualitative), Dispersive power, Rayleigh's criterion, Resolving power of grating and telescope,

**Polarization:** Brewster's law, Malus law, Double refraction (Huygen's theory), Retarders, Quarter and half wave plate, circular and elliptical polarization (Qualitative), Applications: Polaroid goggles and 3D – Movies, Liquid Crystal Display (LCD),

**Unit 2: Electron Optics and Special Theory of Relativity**

**(7 Hours)**

**Electron Optics:** Electron motion in electric (parallel and perpendicular - Qualitative) and transverse magnetic field, Crossed Electric and Magnetic Fields (Qualitative), Electrostatic and Magneto-static Focusing (Qualitative), Applications: Cathode Ray Tube, Scanning Electron Microscope,

**Special Theory of Relativity:** Physical Event, Frames of References, Galilean Relativity, Michelson Morley Experiment (Qualitative), Lorentz Transformations of Space, Time and Velocity (Qualitative), Einstein's formulation of special relativity, Length Contraction, Time Dilation, *Relativistic Mass, Momentum, Force, Mass and Energy (Qualitative)*, Applications: e.g. Nuclear, Energy, (Gravitational and Relativistic Time Dilation Effects: Satellite Communication, Global Positioning System (GPS)),

**Unit 3: Quantum Mechanics**

**(6 Hours)**

**Matter Waves:** Revision to limitations of classical mechanics (Rutherford's atomic model, Black body radiation, Photoelectric effect, Bohr atom model) and need of quantum mechanics, Wave particle duality, de-Broglie's hypothesis, Davisson - Germer Experiment, Braggs law, Phase velocity, Group velocity (Qualitative), Heisenberg's uncertainty principle, Single slit electron diffraction, Applications of uncertainty principle,

**Wave Equations:** Wave function ( $\psi$ ), Max Born's interpretation, Physical significance of  $\psi$  and  $\psi^2$ , Schrödinger's wave equations (Qualitative) and its applications: 1 D - Infinite potential well, Finite potential well (Qualitative), Tunneling effect: Tunnel Diode, Scanning Tunneling Microscope (STM),

**Unit 4: Semiconductor Physics**

**(7 Hours)**

**Semiconductors:** Quantum numbers, Band Theory of Solids, Energy Bands in C (Graphite, Diamond), Si, Ge, Sn, Ohm's Law (Microscopic), Direct and Indirect Band gap, Temperature Dependence of Conductivity, Hall Effect, Fermi Level, Fermi-Dirac Probability Distribution Function, Fermi Level in Intrinsic (derivation) and Extrinsic Semiconductors (Effect of Temperature and Doping Level on Fermi Energy), Working of p-n Junction Diode from Energy Band Diagrams, Light Emitting Diode, Photovoltaic Effect: Solar Cell Working and Characteristics

**Introductory Nanotechnology:** Nanomaterials, Properties (Quantum size effects: optical, electrical, magnetic, structural and mechanical), 0, 1, 2 Dimensional Nanostructures, Nanomaterial Synthesis Techniques (Physical, Chemical etc.), Applications: Energy, Space, Electronics, Defense, Textile, Cosmetics, Medical, Environment, Automobiles,

**Unit 5: Lasers and Fiber Optics**

**(7 Hours)**

**Lasers:** Stimulated Absorption, Spontaneous and Stimulated Emission, Population Inversion, Basic Requirements for Lasing Action, Laser Properties, Ruby Laser, He-Ne Laser, Semiconductor Diode Laser (Principle, Construction and Working), Applications: (Industry : Drilling, Welding and Micromachining, Medical: Laser Eye, Skin, Cosmetic Surgery, Military Applications: Laser range detection, Laser Guided Missiles), Holography: Recording and reconstruction of hologram, applications,

**Fiber Optics:** Optical Fiber, Total Internal Reflection, Acceptance Angle and Cone, Fractional Refractive Index Change, Numerical Aperture, Modes of Propagation, Types of Optical Fibers, Losses in Optical Fiber, Applications: Fiber Optics Communication System, Fiber Optic Sensors,

**Unit 6: Magnetic Materials and Superconductivity**

**(6 Hours)**

**Magnetic Materials:** Magnetic field (B), Permeability, Magnetic Field Strength (H), Magnetic Susceptibility, Magnetization, The Bohr Magnetron, Curie's Law, Hysteresis, Magnetic materials: Dia, para, ferromagnetic, ferrimagnetic, Applications: Transformer cores, Electromagnetic shielding, Magnetic memory storage devices,

**Superconductivity:** Properties (Zero Resistance, Meissner Effect, Critical Fields, Persistent Currents, Critical Current Density, London Penetration Depth, Isotope Effect), Type I and II Superconductors, BCS Theory, High  $T_c$  Superconductors and its preparation, DC and AC Josephson Effect, Applications: Superconducting Quantum Interference Devices (SQUID), Superconducting Computer, Transmission Lines, Superconducting Magnets, Maglev Trains etc.

**List of Practical: (Students will perform any Five experiments as per following code of conduct in physics laboratory)**

Sr. No.	Name of the Experiment	Mode of Conduct
1.	Determination of Wavelength of Light using Michelson's Interferometer	Any one of two / three to be performed by students and other for demonstration of working principle.
	Use of diffraction grating for the determination of wavelength of spectral line and determination of resolution of spectral lines using diffraction grating and spectrometer	
2.	Polarization by Refraction: Malus Law	
	Determination of Brewster's angle for glass surface and refractive index of glass.	
	Demonstration of Lissajous figures using a CRO (Principle of interference) concepts of polarization – Plane, Circular and Elliptical Polarization	
3.	Determination of band gap of a semiconductor.	
	Hall Effect, determination of Hall coefficient.	
4.	Characteristics of solar cell, calculation of fill factor.	
	Study of diode characteristics (PN, Zener, Tunnel, Photodiode, Light Emitting Diode etc. )	
5.	Determination of wavelength and thickness of wire using LASER and determination of beam divergence of LASER.	
	Optical fibre communication system	
6.	Course Project Work	Projects will be allotted in groups at

7.	Course Project Work	the beginning of semester.
8.	Course Project Work	
9.	Course Project Work	
10.	Course Project Work	
11.	Course Project Work	
12.	Course Project Work	

In addition to above experiments students must perform the following all experiments in virtual laboratory environment which is developed by Amrita Vishwa Vidyapeetham under the NME ICT initiative of MHRD, Government of India.

Sr. No.	Name of the Experiment	Link
1	Michelson's Interferometer-Refractive index of glass plate	<a href="http://vlab.amrita.edu/?sub=1&amp;brch=189&amp;sim=1519&amp;cnt=1">http://vlab.amrita.edu/?sub=1&amp;brch=189&amp;sim=1519&amp;cnt=1</a>
2	Michelson's Interferometer-Wavelength of laser beam	<a href="http://vlab.amrita.edu/?sub=1&amp;brch=189&amp;sim=1106&amp;cnt=1">http://vlab.amrita.edu/?sub=1&amp;brch=189&amp;sim=1106&amp;cnt=1</a>
3	Diffraction Grating	<a href="http://vlab.amrita.edu/?sub=1&amp;brch=281&amp;sim=334&amp;cnt=1">http://vlab.amrita.edu/?sub=1&amp;brch=281&amp;sim=334&amp;cnt=1</a>
4	Brewster's Angle determination	<a href="http://vlab.amrita.edu/?sub=1&amp;brch=189&amp;sim=333&amp;cnt=1">http://vlab.amrita.edu/?sub=1&amp;brch=189&amp;sim=333&amp;cnt=1</a>
5	Emission spectra	<a href="http://vlab.amrita.edu/?sub=1&amp;brch=195&amp;sim=359&amp;cnt=1">http://vlab.amrita.edu/?sub=1&amp;brch=195&amp;sim=359&amp;cnt=1</a>
6	Photoelectric effect	<a href="http://vlab.amrita.edu/?sub=1&amp;brch=195&amp;sim=840&amp;cnt=1">http://vlab.amrita.edu/?sub=1&amp;brch=195&amp;sim=840&amp;cnt=1</a>
7	Determination of Planck's Constant	<a href="http://vlab.amrita.edu/?sub=1&amp;brch=195&amp;sim=547&amp;cnt=1">http://vlab.amrita.edu/?sub=1&amp;brch=195&amp;sim=547&amp;cnt=1</a>
8	Hall effect experiment:- Determination of charge carrier density	<a href="http://vlab.amrita.edu/?sub=1&amp;brch=282&amp;sim=879&amp;cnt=1">http://vlab.amrita.edu/?sub=1&amp;brch=282&amp;sim=879&amp;cnt=1</a>
9	Characteristics of Zener diode	<a href="http://vlab.amrita.edu/?sub=1&amp;brch=282&amp;sim=1522&amp;cnt=1">http://vlab.amrita.edu/?sub=1&amp;brch=282&amp;sim=1522&amp;cnt=1</a>
10	Solar Panel Experiment (Remote Trigger)	<a href="http://vlab.amrita.edu/?sub=1&amp;brch=195&amp;sim=360&amp;cnt=1">http://vlab.amrita.edu/?sub=1&amp;brch=195&amp;sim=360&amp;cnt=1</a>
11	Laser beam divergence and spot size	<a href="http://vlab.amrita.edu/?sub=1&amp;brch=189&amp;sim=342&amp;cnt=1">http://vlab.amrita.edu/?sub=1&amp;brch=189&amp;sim=342&amp;cnt=1</a>
12	Numerical Aperture of Optical Fiber	<a href="http://vlab.amrita.edu/?sub=1&amp;brch=189&amp;sim=343&amp;cnt=1">http://vlab.amrita.edu/?sub=1&amp;brch=189&amp;sim=343&amp;cnt=1</a>
13	B-H Curve	<a href="http://vlab.amrita.edu/?sub=1&amp;brch=282&amp;sim=1507&amp;cnt=1">http://vlab.amrita.edu/?sub=1&amp;brch=282&amp;sim=1507&amp;cnt=1</a>
14	Magnetic Material Characterization via Hysteresis (Remote Trigger)	<a href="http://vlab.amrita.edu/?sub=1&amp;brch=195&amp;sim=800&amp;cnt=1">http://vlab.amrita.edu/?sub=1&amp;brch=195&amp;sim=800&amp;cnt=1</a>

**Text Books:**

1. M.N. Avadhanalu, P.G. Kshirsagar; *A Textbook of Engineering Physics, Revised Edition 2014*, S. Chand Technical Publishers, New Delhi,
2. A. Beiser, *Concepts of Modern Physics, (6<sup>th</sup>) New 2005*, Tata McGraw Hill Pub. Co., New Delhi,
3. H. K. Malik, A. K. Singh, *Engineering Physics, 2010*, Tata McGraw Hill, New Delhi,



**Reference Books:**

1. *R. J. Serway and J. W. Jewett, Physics for Scientists and Engineers with Modern Physics, 5<sup>th</sup> / 6<sup>th</sup> / 7<sup>th</sup> Edition 2010, Thomson / Cengage Learning, New Delhi,*
2. *Young and Freedman, University Physics, 10<sup>th</sup> / 11<sup>th</sup> / 12<sup>th</sup> / 13<sup>th</sup> Edition, Pearson Education*
3. *Resnick and Halliday, Fundamentals of Physics, 8<sup>th</sup> / 9<sup>th</sup> / 10<sup>th</sup> Edition, John Wiley and Sons.*

**Course Outcomes:**

The student will be able to –

1. Distinguish, analyze, determine the physical terms from thin film interference, diffraction, polarization and to measure experimentally (wavelength, spectral resolution etc.)
2. Justify, infer, differentiate, calculate terms related to electron motion in electric, magnetic fields while mass, space, time, velocity, momentum, energy, mass – energy equivalence etc.) in relativistic situations and experiment on CRO.
3. Recognize, effectuate, utilize, the fundamental principles of quantum mechanics to solve problems and to interpret the applications in the quantum regime.
4. Derive, draw, evaluate, compute the physical terms in semiconductor physics (Fermi Energy, Energy band diagrams etc.), and to experiment the basic semiconductor devices (e.g. solar cell, pn junction diode etc.) and differentiate, analyze the properties at nano scale, nanomaterials and interpret their applications.
5. Differentiate, correlate, different lasers (e.g. He-Ne laser, Ruby laser etc.) construe their working mechanism, also analyze, evaluate the fundamental terms in fibre optics (e.g. acceptance angle, numerical aperture etc.) their applications, experiment (on lasers fibre optics).
6. Analyze, interpret, distinguish and calculate the basic terms, properties related with magnetism (magnetization, magnetic moment etc.) and superconductivity (e.g. critical temperature, penetration depth etc.) and elucidate their applications.

**Course Name: Engineering Foundations**

**Course Code: ME103TH**

**Course Type: TH**

**Credits: 3**

**Teaching Scheme: Theory : 03 Hours / Week**

**Unit 1: Drives and Mechanisms**

**(7 Hours)**

Power transmission devices: Construction, working, comparison and applications of Belt drive (numerical), rope drive, chain drive, gear drive

Mechanisms: Kinematic link, pair, chain, mechanisms and inversions

**Unit 2: Heat transfer**

**(7 Hours)**

Modes of heat transfer:

Conduction: Fourier laws of heat conduction, Heat conduction through plane and composite walls

Convection: Mechanism, classification of fluid flows, Newton's law of cooling, Nusselt number, Velocity and thermal boundary layer, Prandtl number, Reynold's number

Radiation: basic concepts, Stephen-Boltzman's law, kirchhoff's law, Planck's law and Wien's law

**Unit 3: Introduction to Automobiles and I.C. engines**

**(6 Hours)**

Automobiles: Introduction, classification and basic parts of automobile, Classification of I.C. engines, Construction and Working of - 4 stroke petrol engine, 4 stroke diesel engine and 2 stroke petrol engine.

**Unit 4: General Introduction and Building Materials**

**(7 Hours)**

General introduction of civil engineering and its branches, introduction to components, types of building structures – Load bearing, framed and composite.

Principles of planning: - aspect, prospect, privacy, roominess, grouping, circulation, flexibility, elegance, furniture requirements, sanitation, orientation, economy.

Building materials and measurements: - types and grades of cement and concrete, Ready Mix Concrete (RMC), Steel – types and sections used in construction, sand, aggregates, bricks, stones, glass, timber.

**Unit 5: Building Services**

**(6 Hours)**

Building Services: - Water supply, drainage, sanitary requirements, Elevators, Escalators, ramps, Sound proofing, intelligent buildings etc. Heating, ventilation and air conditioning (HVAC) system, Mechanical, electrical, and plumbing (MEP) system, Integrated Building Management Systems (IBMS) system, Infrastructure development, Transportation - Road, Rail, Air, Water transportation.

Introduction to GIS, GPS and remote sensing.

**Unit 6: General Requirements and Bye Laws**

**(7Hours)**

Zones of buildings: Residential, commercial, industrial, agricultural, public, no development zone. Site selection with its requirements, procedure for obtaining development permission, procedure during construction.

Building Bye Laws: Building line, height of buildings, open space requirements, setback, ventilation, sanitation, built up area, carpet area, Floor Space Index (FSI), Floor Area Ratio (FAR), Transfer of Development Rights (TDR), Land registration, 7/12 extract, (RERA Act) - Real Estate Regulation and Development) Act, 2016.

**Text Books:**

1. *S S Rattan, 'Theory of Machines', Fourth Edition, Tata Mcgraw-Hill.*
2. *R K Rajput, 'Thermal Engineering', Ninth Edition, Laxmi Publications, Delhi.*
3. *Kirpal Singh, 'Automobile engineering', Thirteenth Edition, Standard Publishers, Delhi.*
4. *Dr. B. C. Punmia; Basic Civil Engineering, Laxmi Publications (P) Ltd.*
5. *S. S. Bhavikatti, Basic Civil and Environmental Engineering, New Age International Publishers.*

**Reference Books:**

1. *V Ganeshan, 'Internal Combustion Engines', Third Edition, Tata McGraw-Hill.*
2. *Dr. B. C. Punmia; Building Construction, Laxmi Publications (P) Ltd.*
3. *Er. Shrikrishna A. Dhale, Basic of Civil Engineering, S. Chand Publication.*

**Reference Document:-**

1. *Standardised Development Control and Promotion Regulations for Municipal councils and Nagar Panchayats in Maharashtra, Sanctioned vide govt. notification, Dt. 21st November 2013.IDE*

**Course outcomes:**

At the end of this course, student will be able to-

1. Understand various mechanical drives and learn basics of mechanisms.
2. Understand different modes of heat transfer and their governing laws.
3. Understand working principles of I.C. Engines.
4. Acquire the knowledge of building structures, planning aspects and construction materials.
5. Gain the knowledge of different building services.
6. Understand basic real estate terms and building Bye laws.

**Course Name: Engineering Mechanics**

**Course Code: ES107TH**

**Course Type: TH**

**Credits: 3**

**Teaching Scheme: Theory : 03 Hours / Week**

**Unit 1: Basics of Mechanics:**

**(7 Hours)**

Types of Mechanics, historical development, Fundamental concepts (Length, mass, time, Force, concentrated force, surface forces, body forces, internal and external force, push and pull force, Action and Reaction, Tension and Compression force, weight, idealization as a particle and rigid body), six fundamental principles of mechanics (Newton's 3 laws of motion, Law of gravitation, Law of Parellogram, Principle of transmissibility), SI units, prefixes & their conversions, Vector operations, scope of study, Various force systems.

**Coplanar Force System:** Skew resolution and composition of force, Rectangular resolution and composition of force, resultant of concurrent force system, equilibrium of a particle, free body diagram of particle, Use of lamis theorem. Moment of force, Principle of moments/Varignon's theorem, couple & its properties, Conversion of force in to force & couple, equivalent force couple system,

**Unit 2: Non-coplanar Force System:**

**(6 Hours)**

Rectangular components of a force, co-ordinate direction angles, direction cosines, unit vector, addition of vectors, position vector, Force defined by its magnitude and two points on its line of action, application of dot product, Resultant and equilibrium of concurrent force system, cross product, Moment of force about a point & about an axis, Resultant and equilibrium of parallel force systems.

**Unit 3: Equilibrium:**

**(7 Hours)**

Conditions of equilibrium in coplanar and non coplanar force system, types of supports and support reaction ,types of loading, Free body diagram, support reactions of determinate beams (simply supported, cantilever, overhang, compound), equilibrium of two force body & equilibrium of three force body, equilibrium of parallel and general forces in plane.

**Unit 4: Distributed Forces:**

**(6 Hours)**

**Centroid:** concept of center of mass, center of gravity & centroid, use of Varignon's theorem of moment, application of standard formulae to find centroid of composite plates and wires,

**Moments of Inertia:** Concept & its significance, parallel & perpendicular axis theorems, polar moments of inertia, radius of gyration, application of standard formulae to find M.I. of simple and composite areas.

**Unit 5: Analysis of Structures:**

**(8 Hours)**

**Plane truss:** Concept of plane and space truss, two force and multi force member, perfect, imperfect, deficient, redundant plane truss, assumptions in analysis of truss, method of joints ,zero force member, method of section

**Frames:** Analysis of plane frames

**Friction:** concept of friction, Coulomb's laws of dry friction, limiting force of friction, coefficient of friction, angle of friction, angle of repose, cone of friction, variation of frictional force for various conditions (no friction, no motion, impending motion and motion conditions),Wedge friction, problems on dry friction( with no impending motion, impending motion at all points of contact, impending motion at some point of contact).

**Unit 6: Kinematics of a particle:**

**(6 Hours)**

**Rectilinear motion:**

Definition of motion, types of motion (plane, space, translation, rotation, general plane motion). Concept of position, displacement, distance, speed, average & instantaneous velocity and acceleration, uniform motion, uniformly accelerated motion, constant acceleration equations, gravitational motion & its equations.

Variable acceleration: primary and secondary equations of motion, general approach for determination of motion of a particle, Numericals on variable acceleration. Graphical solution of rectilinear motion, and other graphical methods

**Curvilinear motion:**

Motion along plane curved path, Concept of position, displacement, distance, speed, average & instantaneous velocity and acceleration, curvature, radius of curvature, point of inflexion.

Application to find velocity and acceleration in three systems: rectangular coordinate (x-y), normal and tangential (n-t), radial and transverse (r- $\theta$ ).

**Text Books:**

1. R. C. Hibbeler; *Engineering Mechanics Statics & Dynamics*, Pearson Publication, 12<sup>th</sup> edition
2. F. P. Beer and E. R. Johnston; *Vector Mechanics for Engineers Statics & Dynamics- 9<sup>th</sup> edition*, Tata McGraw-Hill Publications.
3. J. L. Meriam, L. G. Kraige; *Engineering Mechanics Statics & Dynamics - 5<sup>th</sup> edition*, John Wiley & Sons, Inc. Publication.

**Reference Books:**

1. E.W. Nelson; *Schaum's Outlines : Engineering Mechanics Statics & Dynamics*, McGraw-Hill Publications.
2. R. C. Hibbeler; *Engineering Mechanics Statics & Dynamics*, Pearson Publication.

**Course Outcomes:**

After successful completion of this course, students will be able to

1. Evaluate resultant, moment of force and apply equilibrium equations to coplanar force system.
2. Determine resultant, moment of force and apply equilibrium equations for Non-coplanar force system.
3. Apply equilibrium equations to beams and simple frictionless rigid body assemblies to determine unknowns.
4. Determine the centroid and second moment of area of simple and composite lamina.
5. Analyze co-planar systems of forces to determine the forces in members of trusses, frames and assemblies including friction.
6. Analysis of motion of the particle along rectilinear and curved path

**Course Name: Engineering Drawing**

**Course Code: ME101THL**

**Course Type: THL**

**Credits: 3**

**Teaching Scheme: Theory : 02 Hours / Week**

**Lab : 02 Hours /Week**

**Unit 1: Orthographic Projections**

**(7 Hours)**

Reference Planes, Types and Methods of projections with symbols, Projections of various objects, various types of sectional views.

**Unit 2: Isometric Drawing**

**(5 Hours)**

Types of pictorial projections, isometric Projections and Isometric views, Construction of Isometric views from given orthographic views.

**Unit 3: Projections of points**

**(3 Hours)**

Projections of points in various quadrants

**Unit 4: Projections of lines**

**(4 Hours)**

Projections of lines inclined to both reference planes (lines in first quadrant only), locating traces of lines.

**Unit 5: Projections of planes**

**(4 Hours)**

Projections of planes inclined to both reference planes.

**Unit 6: Projections of Solids**

**(5 Hours)**

Projections of Solids: Classification of solids, Projections of solids such as Prism, Pyramids, Cylinder, Cone, Cube, and tetrahedrons inclined to both reference planes.

**List of Practical:**

**1. Introduction to Lines, Lettering and Dimensioning**

Students will learn various types of lines and their applications. They will also learn various standard practices of dimensioning and Lettering.

**2. Orthographic Projections**

Students will draw sectional orthographic projections of simple machine components.

**3. Isometric Drawing**

Students will draw isometric drawings of simple machine components.

**4. Computer aided drafting with AUTO CAD**

- a. Introduction, advantages and applications of CAD, drawing, editing and modifying
- b. Assigning annotations, dimensioning and line properties
- c. Practice problems

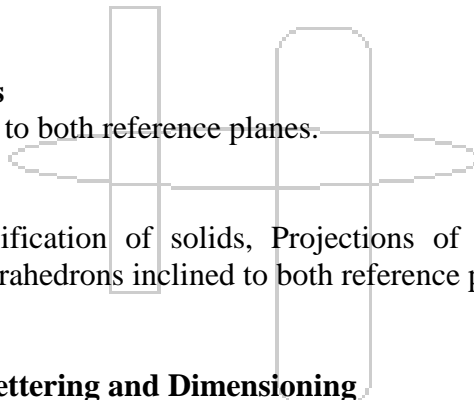

**Text Books:**

1. *N. D. Bhatt; Engineering Drawing; 50th edition, Charotar Publication.*
2. *Dhananjai A. Jolhe; Engineering Drawing with an introduction to AUTOCAD; 5th edition, Tata McGraw Hill education pvt.ltd., New Delhi.*
3. *C. M. Agawal, Basant Agrawal; Engineering Drawing; 2nd edition, Tata McGraw Hill education pvt.ltd., New Delhi.*
4. *Sham Tickoo; CATIA V5-6R2014 for Engineers and Designers; Dreamtech press.*

**Reference Books:**

1. *Warren J. Luzzader ; Fundamental of Engineering Drawing; Prentice Hall of India, New Delhi.*
2. *Venugopal K; Engineering Drawing and Graphics; New Age Internation Publishers.*
3. *K. L. Narayana and P. Kannaiah; Text book of Engineering Drawing; Scitech Publications, Chennai.*

**Course Outcomes:**

The student will be able to –

1. To learn standard practices of lines, lettering and dimensioning in Engineering Drawing.
2. Visualize and draw orthographic projections of 3D object manually and with CAD tool.
3. Visualize the object and draw isometric views for simple machine components
4. To plot the projection of points and lines
5. To draw the projection of planes
6. To draw the projection of solids.

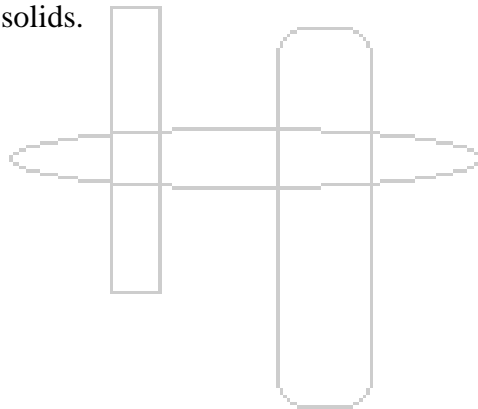

**Course Name: Behavioral Sciences**

**Course Code: HS152TH**

**Course Type: TH**

**Credits: 2**

**Teaching Scheme: Theory : 02 Hours / Week**

**Unit 1: Title of the Unit: Foundations of Psychology (4 Hours)**

Definition and goals of Psychology, Scientific methods – Laboratory Experiment, Field work, Archival research, survey, Interview, Application of Psychology - Educational Psychology, Social Psychology, Developmental psychology, Health/clinical Psychology

**Unit 2: Title of the Unit: Development of Human Behavior (6 Hours)**

Personality Development: Nature and Nurture, Theories - Erikson, Big Five (Trait), Measurement – Projective techniques (Rorschach, TAT), Personality Inventories, and Application: Family Psychology

**Unit 3: Title of the Unit: Cognition (4 Hours)**

Perception, Attention, basic concepts of Psychophysics, Memory and forgetting: Models and theories, Application: Educational Psychology

**Unit 4: Title of the Unit: Motivation (6 Hours)**

Definition of Motivation and the motivational cycle, Theories of Motivation: Drive, Incentive, McClelland, Maslow, Frustration and conflict: Sources and Types, Application : Industrial Psychology

**Unit 5: Title of the Unit: Intelligence (4 Hours)**

Definition, measurement and Theories of Intelligence, Concept and models of EQ, Application: Testing and Counselling

**Unit 6: Title of the Unit: Individual and Group behavior (6 Hours)**

Group behavior: Compliance, Conformity, Theories of attraction, Love and relationships, Anti-social behavior: causes and remedies, Application: Social, Consumer and Criminal Psychology

**Text Books:**

1. *Clifford T. Morgan and Richard A. King; Introduction to Psychology; 7<sup>th</sup> edition, Tata McGraw Hill Publication*
2. *Robert Feldman; Understanding Psychology; 10<sup>th</sup> edition, Tata McGraw Hill Publication.*

**Course Outcomes:**

Students will be able to

1. Understand and apply psychological principles to personal life and will implement the concepts of Psychology in day to day life.
2. Get insight into their own personalities and develop it under the guidance of various theories.
3. Learn the methods to improve their interfamily relationships.
4. Identify the individual differences in motivation and range of emotion. And demonstrate the application self motivation and emotional regulation.
5. Differentiate between intelligence and aptitude and understand about IQ.
6. Equipped with various learning methodologies and resolve problems with a creative outlook.



**Course Name: German**

**Course Code: HS102TH**

**Course Type: TH**

**Credits: 2**

**Teaching Scheme: Theory : 02 Hours/ Week**

**Unit 1: Introduction to German (4 Hours)**

Alphabets and sounds. International words in German. Introducing oneself and others. Times of the day. Greetings according to time of the day. Listening to conversations in day life situations, Cities and countries. Nationalities and languages.

**Grammar:** Personal pronouns. Conjugations of weak verbs.

**Unit 2: Friends Colloques Professions and responsibilities (6 Hours)**

Introducing various professions and different professions, professional life. Responsibilities at the workplace. Small Passages and Dialogues related to that. Classroom related objects, Numbers. 1-1000. Tell and understand telephone numbers. Dates.

**Grammar:** Conjugation of verbs sein and haben (to be and to have), Singular and Plural form of nouns. Definite articles.

**Unit 3: In the city (4 Hours)**

Places in Germany, Vocabulary related to different places in the city like Railway station , Museum, Busstop etc. Directions and telling location. Family and relationships.

**Grammar:** Indefinite Articles, Negation, Strong Verb, Imperative

**Unit 4: Food and drinks (4 Hours)**

Starting conversations. Meeting in Cafes. Vocabulary for food and drinks. Ordering food and paying the bill.

**Grammar:** Nominative, Akkusative, Verbs associated with Nom and Akk. Forming and answering Wh questions. Introduction of Modal Verb möchten

**Unit 5:Time (5 Hours)**

Learning clock hours, Taking formal appointments and casual meetings. Describing daily routine .Giving excuses for delays and absence. Professions and the describing responsibilities involved in that professions.

**Grammar:** Possessive pronouns. Separable verbs, Modal verbs müssen, können, wollen

**Unit 6: Hobbies, Journey, Trip, Excursion (3 Hours)**

Hobbies and free time activities. Journey, small trips

Mode of transport for the same .

**Grammar:** Akkusative, Präpositionen of Akkusative Introduction of Dativ, ordinal numbers

**Unit 7: Living in Germany (4 Hours)**

Types of Houses , Types of Rooms, Description of rooms.Vocabulary of Furniture in the house.

**Grammar:** Adjectives, Opposites, Wechsel Präpositionen

**Text Books:**

1. *Netzwerk Deutsch als Fremdsprache A1* by Stefanie Dengler

**Course Outcomes:**

The student will be able to –

1. Pronounce the words correctly according German language rules and formulate small and simple sentences in German using basic grammar structures. Introduce himself or herself
2. Say, write numbers, number names. Recognize professions of male and female. Play dialogs related to classroom object. Recognize definite articles of classroom objects. Recognize Singular/Plural form.
3. Tell directions, locations. Write passage on Family and professions, ages of family members. Write, formulate negation sentences. To give orders, make polite requests using Imperative.
4. Make conversation related to Restaurant, Cafes using Accusative and Modal verb (möchten)
5. Read and tell clock time and use it for taking and cancelling formal/ informal appointments using Possessive pronouns, Separable verbs and Modal verbs.
6. Read and understand small texts about Hobbies, free-time activities and read and write ordinal number, date of birth and important days, holidays in year. Recognize and use Accusative prepositions
7. Describe various types of houses and furniture items in various rooms of a house

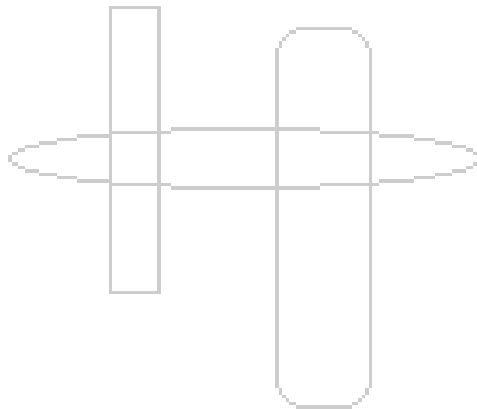

**Course Name: French**

**Course Code: HS105TH**

**Course Type: TH**

**Credits: 2**

**Teaching Scheme: Theory : 02 Hours/ Week**

**Unit 1: Introduction**

**(4 Hours)**

Alphabets, Numbers (0-100), Months, days of the week, Difference between Tu/Vous, Self Introduction, Date of birth, Telephone numbers, Basic salutations.

**Unit 2 Ecole de francais, Paris: Au secrétariat**

**(6 Hours)**

Indefinite Articles (c'est ce sont) Definite Articles, Introduction of third person, Nationalities, professions, Irregular verbs –Etre / Avoir.

**Unit 3: Autour de l'école**

**(4 Hours)**

Vocabulary related to family and colours, Regular « er » ending verbs, Prepositions, Directions.

**Unit 4: La vie quotidienne**

**(6 Hours)**

Quelle heure est- il?, Verbs « aller, venir, faire », Interrogation (yes /no), Reflexive verbs.

**Unit 5: Ma chambre**

**(6 Hours)**

Vocabulary for room and house, Regular “ir” ending verbs, Concept of si, oui and non, Les adjectifs possessifs.

**Unit6: Une Randonnée**

**(4 Hours)**

La négation, Concept of Jouer a/jouer de.

**Text Books:**

1. *Manjiri Khandekar and Roopa Luktuke; JUMELAGE; Saraswati House Pvt Ltd.*

**Course Outcomes:**

The student will be able to –

1. Greet formally as well as informally and introduce himself or herself in French, Read and write numbers, dates, telephone numbers, days of the week.
2. Describe the culture of France and form grammatically correct sentences and introduce third person.
3. Ask or tell the directions to reach the destination and describe your family.
4. Tell and ask time, frame basic questions and describe your routine.
5. Write emails, letters and small essays in French and describe your room using relevant vocabulary.
6. Make negative sentences and use them in the dialogues.

**Course Name: Japanese**

**Course Code: HS103TH**

**Course Type: TH**

**Credits: 2**

**Teaching Scheme: Theory: 02 Hours/ Week**

**Unit 1: Orientation ( Jikoushokai, Aisatsu & Moji ) (6 Hours)**

- Theory: Orientation Lecture
- Introduction of Hiragana script with basic words
- Youon, Sokuon, Chouon – Methods of writing words
- Greetings and Classroom Expressions
- Etiquettes and mannerisms

**Unit 2: Introduction Of Katakana ( Moji Katakana ) (4 Hours)**

- Introduction of Katakana script
- Introduction of Katakana rules
- Katakana words used in daily life

**Unit 3: Calender & Numbers ( Suji, Youbi, Hizuke, Jikaan ) (4 Hours)**

- Introduction of numbers
- Writing Days of the week, Dates, Time, Months in Hiragana
- Special Greetings used in different situations in Japan

**Unit 4: Basic Grammar Pattern ( Bunnokatachi, Keiyoushi-To, Doushi ) (4 Hours)**

- Introduction of ~は~です pattern
- Affirmative, Negative and interrogative sentences
- Introduction of demonstrative pronouns
- Learning い and な adjectives and opposites
- Introduction of some basic and useful verbs and their simple present tense

**Unit 5: Introduction Of 3<sup>rd</sup> Script Kanji ( Kanji & Kanji Jukugo) (6 Hours)**

- Basics of Kanji
- Kanji for Numbers (1-10)
- Kanji for basic words

**Unit 6: Culture Of Japan ( Nihon-No-Bunka ) (4 Hours)**

- Some festivals in Japan
- Arts of Japan
- Foods and Dress of Japan
- Islands and seasons of Japan
- Some special things about and in Japan
- Revision of all topics and paper

**Text Books:**

1. *Nihongo Shoho; Japanese Language Teachers Association pune; April 1994.*
2. *Minnano Nihongo; Goyal Publisher; 2012*

**Course Outcome :**

The Student will be able to :

1. Greet formally and introduce himself/herself in Japanese language with appropriate etiquettes and mannerism.
2. Read and write Hiragana, Katakana, Scripts along with basic words, numbers, dates, telephone nos., days of the week, months, year, and time.
3. Read and write 3<sup>rd</sup> Script Kanji i.e Kanjis for nos., Days, dates, time, years as well as some basic words.
4. Read/Write sentences using basic sentence pattern including all three scripts.
5. Tell about his/her family. Describe things using basic adjectives and actions by using basic verbs.
6. They become familiar to fascinating country like Japan & Japanese culture.

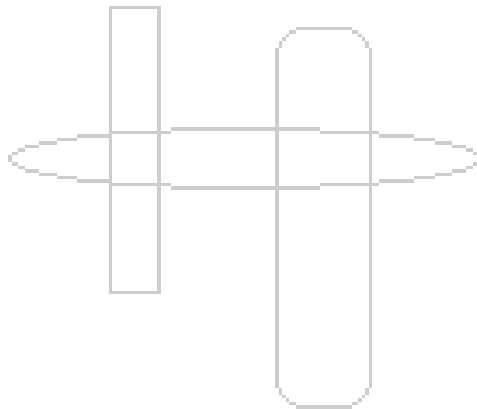

**Course Name: Chinese**

**Course Code: HS106TH**

**Course Type: TH**

**Credits: 2**

**Teaching Scheme: Theory : 02 Hours/ Week**

**Unit 1: Introduction to Chinese Characters (8 Hours)**

The basic strokes – heng, shu, pie, na, dian, ti ; 22 derivative strokes; Numbers; words & Characters

**Unit 2: Everyday Activities (4 Hours)**

Home life, school routine, Eating and drinking, Health and fitness

**Unit 3: Personal and social life (4Hours)**

Self, family, personal relations, pets, everyday life, eating out, holidays

**Unit 4: World around us (5Hours)**

Clothes, shopping, public services, customs, weather, finding the way, meeting and greeting related phrases, travel and transport, animals, birds etc.

**Unit 5: Time (4 Hours)**

Learning clock hours, Taking formal appointments and casual meetings. Describing daily routine .Giving excuses for delays and absence.

**Unit 6: Hobbies, Journey, Trip, Excursion (5 Hours)**

Hobbies and free time activities. Journey, small trips , Mode of transport, sports, recreation .

**Text Books:**

1. *Netzwerk Deutsch als Fremdsprache A1* by Stefanie Dengler

**Course Outcomes:**

The student will be able to –

1. Write basic Chinese characters
2. Pronounce the words correctly according Chinese language rules Introduce himself or herself
3. Say, write numbers. Recognize professions
4. Tell directions, locations. Write passage on Family and professions, ages of family members. Write, formulate negation sentences.
5. Read and tell clock time and use it for taking and cancelling formal/ informal appointments

**Course Name: Sanskrit**

**Course Code: HS104TH**

**Course Type: TH**

**Credits: 2**

**Teaching Scheme: Theory : 02 Hours/ Week**

**Unit 1:**

**(6 Hours)**

Sanskrit as a language. (listening skills), Why Sanskrit? Introduction to Technical aspects, Methods of using Sanskrit as a Knowledge bank.

**Unit 2:**

**(4 Hours)**

Sentence construction, Usage, Numbers, Varnas, Rules of writing, Complex sentences, Shastra, concept.

**Unit 3:**

**(4 Hours)**

Why to speak in Sanskrit?, A language to be experienced.(Vibrations, Mantra), Shabda, Dhatu, Nama, Avyaya, Visheshana.

**Unit 4:**

**(4 Hours)**

Text, reading and explaining in simple Sanskrit, Paragraph writing, Presentation.

**Unit 5 :**

**(3 Hours)**

Comprehension, Tenses and Moods. (Iakaraha 6), Sandhihi (concept)

**Unit 6:**

**(3 Hours)**

Samasa (Concept), Pratyayavichar.(concept)

**Text Books:**

1. Dhaturupachandrika
2. Rachananuvaadakaumudi

**Course Outcomes :**

The Student will be able to:

1. Understand and experience the importance of Sanskrit in Research and Development.
2. Make small sentences and express themselves in Sanskrit.
3. Can read simple text.
4. Understand some grammatical concepts and use them.
5. Try to read some part of ancient text to choose some project.
6. Know simple Sanskrit, they get confidence for further study

**Course Name: Soft Skills and Seminar**

**Course Code: HS153L**

**Course Type: L**

**Credits: 1**

**Teaching Scheme: Lab : 02 Hours/ Week**

**Unit 1: Introduction to soft skills and writing skills (4 Hours)**

Goal setting and career planning: dreams and goals; Short term, medium and long term goals. Setting SMART goals, Introduction and meaning of soft skills; difference between soft skills and hard skills, importance of soft skills in corporate world, Concepts of IQ, EQ and SQ, SWOT (activity based explanation), Application, email, Report (Informal) writing.

**Unit 2: Professional etiquettes (4 Hours)**

Etiquettes and manners: meaning and significance, Attitude, organizational ethics, Telephonic etiquettes, table manners, professional etiquettes, hygiene and clothing manners.

**Unit 3: Communication skills (6 Hours)**

Communication skills: Meaning, need, significance and types (written/oral, formal/informal, internal/external etc), Barriers in communication, How to start a communication?, Communication process (Articulation of thought) Concept of KISS(Keep It Short and Simple), Importance of non-verbal communication. Public speaking meaning ,do's and don'ts

**Unit 4: Listening skills (4 Hours)**

Meaning, difference between listening and hearing, process of listening, Types: active, passive, evaluative, discriminative listening, intuitive, selective, pretence, Barriers in listening. Physical barriers, People related barriers ( Physiological barriers, Psychological barriers), Tips for being a good listener

**Unit 5: Team building (6 Hours)**

Team building and leadership, Concept of team: difference between team and group, process of team building, significance and methods to develop team spirit, Characteristics of a leader. Walk the talk.

**Unit 6: Time management and Group discussion (6 Hours)**

Time management (Concept and importance), Techniques and rules and regulations during GD, Do's and don'ts in GD.

**Text Books:**

1. *Soft Skills by Dr. K Alex. S.Chand and company ltd.*

**Course Outcomes:**

The student will be able to –

1. Set his / her goals for future and use writing skills for formal documents.
2. demonstrate professional etiquettes in a workplace
3. Apply proper communication skills and hence enable him to be an effective communicator.
4. Become a good listener and perform his / her tasks as per expectations.
5. Lead a team successfully and work as a good team player as well.
6. Apply time management skills and participate in group discussions.



**Course Name: Fundamental Mathematics**

**Course Code: ES157AU**

**Course Type: AU**

**Credits: Audit**

**Teaching Scheme: Theory : 02 Hours / Week**

**Unit 1: Functions, Limits and continuity (4 Hours)**

Elementary functions and their graphs, Inverse functions, Limits, Continuity.

**Unit 2: Derivative (4 Hours)**

Derivative and its geometrical significance, Maxima and Minima, and Mean value theorems.

**Unit 3: Integration (4 Hours)**

Integration as the inverse process of differentiation. Integration by parts and by substitution.

**Unit 4: Definite integral (4 Hours)**

Definite integral, properties, evaluation and its applications.

**Unit 5: First order differential equation (4 Hours)**

Order, degree, types of solution, Formation of differential equations, methods of solving.

**Unit 6: Complex numbers (4 Hours)**

Complex numbers as ordered pairs, Argand's diagram, De Moiver's Theorem, Hyperbolic functions.

**Text Books**

1. Ron Larson and Bruce H. Edwards, 'Text book of Calculus', Brooke/Cole, a part of Cengage Learning ( Indian Edition), (c) 2011.
2. Thomas G. B. and Finney, 'Calculus and analytic Geometry', 11<sup>th</sup> Edition, Pearson Publications

**Reference Books:**

1. Murray R. Spiegel, 'Advanced Calculus', Schaum's out line series, New Delhi, 1st Edition, 1981, McGraw Hill International Book Co.
2. Tom Apostol, 'Calculus', volume-II, 2<sup>nd</sup> Edition, Wiley India Edition
3. Erwin Kreyszig, 'Advanced Engineering Mathematics' 10<sup>th</sup> Edition, Dec. 2010, , John Wiley and sons, Inc

**Course Outcomes:**

The students will be able to

1. Identify and graph the elementary function and their limits
2. find derivative, maxima and minima of functions
3. apply the basic rules of integration
4. solve the problems on definite integral
5. set up and solve the differential equations
6. analyze complex numbers and its geometry

**Course Name: English**

**Course Code: HS101AU**

**Course Type: AU**

**Credits: Audit**

**Teaching Scheme: Theory : 02 Hours / Week**

**Unit 1. Vocabulary**

**(4 Hours )**

- Word Formation
- Correct Usage
- Idiomatic Expressions

**Unit 2. Basic Grammar**

**(6 Hours)**

- Articles
- Parts of Speech
- Sentence Structure
- Verbs and Concord
- Question tags
- short responses

**Unit 3.: Listening Skills**

**(4 Hours)**

- Kinds of Sentences
- Verbs Modals
- Conjunctions

**Unit 4. Speaking Skills**

**(6 Hours )**

- Direct and Indirect speech
- Description
- Narration
- Conversation

**Unit 5. Reading Skills**

**(4 Hours )**

- Active Passive Voice
- Prepositions
- Improved Spelling

**Unit 6. Writing Skills**

**(6 Hours)**

- Paragraph Writing
- Punctuation
- Note-making

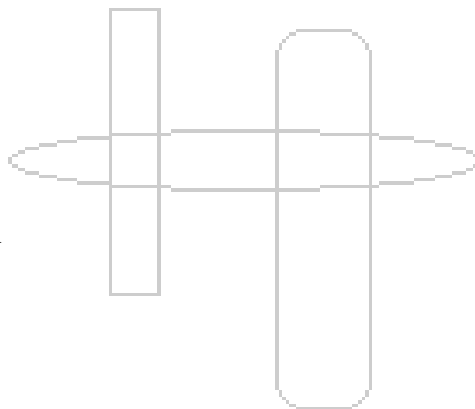

**List of Practicals:**

Sr. No.	Description	Mode of Conduct
1.	Self- Introduction	Use of Audio, video sessions, demonstrations, group activities and games, scene enactments.
2.	Review a film clipping	
3.	Guess the word, Telephonic Conversations	
4.	Dumb Charades	
5.	Dialogues, Situational conversation, Relay conversation.	
6.	Analyse a newspaper article	
7.	Spot the error, clues.	
8.	Newspaper articles, Reports, Editorials.	
9.	Picture Composition	
10.	Paragraph Writing	
11.	Group Activity-follow instructions, enacting.	
12.	Crossword Puzzles, Scramble	
13.	Memory Games.	
14.	Chinese Whispers, Follow Instructions	

**Text Books:**

1. *Wren and Martin, "English Grammer and Composition" S. Chand Publications*

**Reference Books:**

1. *Bansal and Harrison- Spoken English in India*
2. *Essentials of Grammar and Composition*
3. *Lewis- The New Roget's Thesaurus in Dictionary Form*
4. *Oxford English for Careers:Engineering 1 Student's Book. Oxford University Press*

**Course Outcomes:**

The student will be able to –

1. Enhance their vocabulary skills
2. Construct and use grammatically correct sentences.
3. Develop good listening skills.
4. Speak confidently in English.
5. To be able to comprehend the printed content
6. Write appropriately to communicate effectively

**Course Name: Environmental Science**

**Course Code: HS155AU**

**Course Type: AU**

**Credits: Audit**

**Teaching Scheme: Theory : 02 Hours / Week**

**Unit 1 : Nature of environmental studies**

**(6 Hours)**

Definition, scope, importance, multidisciplinary nature of environmental studies, need of public awareness, Role of an individual in conservation and equitable use of natural resources, sustainable lifestyles, Natural resources and associated problems : Forest, water, mineral, food, energy, land resources

**Unit 2 : Ecosystems**

**(4 Hours)**

Concept, Structure, function, characteristics of ecosystems, energy flow in ecosystem, producers, consumers, and decomposers, ecological succession

**Unit 3 : Biodiversity and its conservation**

**(4 Hours)**

Introduction, value, hot spots, of biodiversity, threats to biodiversity, conservation of biodiversity

**Unit 4 : Environment pollution**

**(6 Hours)**

Introduction, definition, types of pollution, cause and effect of pollution, solid waste management, role of an individual in prevention of pollution, disaster management

**Unit 5 : Social issues and the environment**

**(4 Hours)**

Unsustainable to sustainable development, urban problems related to energy, water conservation, environmental ethics, climate change, global warming, ozone layer depletion, wasteland reclamation, consumerism and waste products

**Unit 6 : Environmental protection**

**(6 Hours)**

Environmental protection act, AIR (Prevention and Control of Pollution) Act, Water (Prevention and Control of Pollution) Act, Wildlife protection act, Forest conservation act, population growth and human health, human rights

**Text Books:**

1. *Erich Bharucha;Textbook of Environmental Studies for Undergraduate Courses,Second Edition,UGC Publications.*
2. *Mackenzie L. Davis and David A. Cornwell.2010. Introduction to Environmental Engineering, 4e. Tata McGraw-Hill Education Private Limited New Delhi.*

**Reference Books:**

1. *Gilbert M. Masters.2007. Introduction to Environmental Engineering and Science, 2e. Pearson Education. Dorling Kindersley (India) Pvt. Ltd. Delhi.*
2. *J. Glynn Henry and Gary W. Heinke.2004. Environmental Science and Engineering, 2e. Pearson Education (Singapore) Pte. Ltd.*

**Course Outcomes:**

The student will be able to –

1. Recognize renewable and non-renewable resources and associated problems and plan different activities to create awareness among the people and hence to conserve resources by minimizing degradation of environment.
2. Understand different types of ecosystems and their importance in balancing the nature.
3. Understand concept of biodiversity at national and global level and need to preserve it.
4. Understand different types of pollutions and hence to find the remedial measures to minimize ill effects.
5. Recognize various disaster and solid waste management techniques.
6. Understand and appreciate the ethical, cross-cultural, and historical context of environmental issues and the links between human and natural systems

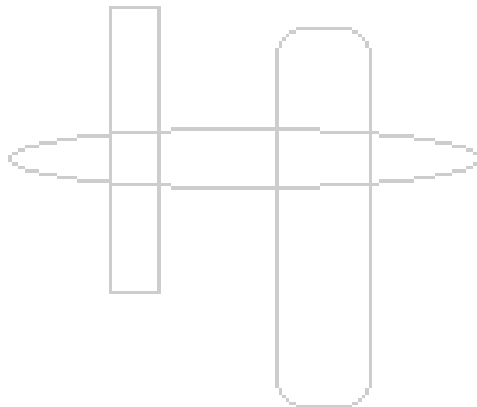

**Course Name: Aerobics**

**Course Code: GP101L**

**Course Type: L**

**Credits: 1**

**Teaching Scheme: Lab: 02 Hours / Week**

**Unit 1 :** (2 Hours)  
Introduction of blocks and beats

**Unit 2 :** (2 Hours)  
Revision of block and beats, introduction of floor exercises

**Unit 3 :** (2 Hours)  
Revision of block and beats, introduction of floor exercises, Introduction of steps

**Unit 4 :** (2 Hours)  
Revision of block, beats, floor exercises, steps, Introduction of choreography

**Unit 5 :** (2 Hours)  
Revision of block, beats, floor exercises, steps, choreography, Introduction of beat caching

**Unit 6 :** (2 Hours)  
Self Choreography

**Course Outcomes:**

The student will be able to –

1. Demonstrate blocks and beats
2. Demonstrate floor exercise
3. Make their own steps
4. Make their own choreography
5. Coordinate their own steps with songs
6. Self independent of aerobic workout

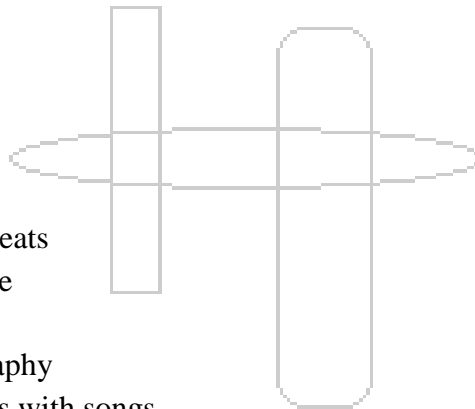

**Course Name: Bharatnatyam**

**Course Code: GP102L**

**Course Type: L**

**Credits: 1**

**Teaching Scheme: Lab: 02 Hours / Week**

**Unit 1 : (5 Hours)**

Basic groups of bharatnatyam ,knowledge about all classical dance style, learning first two groups in three speeds

**Unit 2 : (2 Hours)**

Getting started with hand gestures or Mudras, demonstrations of use of 'Hasta Mudras', saying 'Taal' on your hand

**Unit 3 : (2 Hours)**

Learning 3<sup>rd</sup> and 4<sup>th</sup> groups, introduction to 'Abhinaya' or 9 'emotions' in dance, demonstration of 'Abhinay'

**Unit 4 : (2 Hours)**

Practical learning of 5<sup>th</sup> and 6<sup>th</sup> groups, next level 'Mudras' and uses, knowledge about 'Anarya Abhinaya'

**Unit 5 : (2 Hours)**

Performing 3,4,5,6 in 3 speeds, demonstration of saying steps in different Taals, learning 5 'Gaatis'

**Unit 6 : (2 Hours)**

Small dance drama based on 'Navaras' using all adavus learnt before and setting a dance , saying all steps in different 'Laya' and 'Taals'

**Reference Books:**

1. "Natyashashtra" Bharat Mano
2. "Abhinaydarpana" A.C. Nandikeswara

**Course Outcomes:**

The student will be able to –

1. Perform the basic steps of bharatnatyam
2. Demonstrate 'Mudras' and their uses in dance.
3. Perform the groups in different speeds.
4. Use the 9 Emotions in dance
5. Set up or choreograph a small dance piece on music
6. Set up a dance drama in groups set to music

**Course Name: Chess**

**Course Code: GP103L**

**Course Type: L**

**Credits: 1**

**Teaching Scheme: Lab: 02 Hours / Week**

**Unit 1: (5 Hours)**

Origin of the game, Setting up the board, How to move pieces, **Notation**, Basic Notation, Special Notation(castling, capturing of pieces), **Special Moves**, Castling, En-passant, How a game is won, How a game is drawn, Types of draw

**Unit 2: Basic concepts (5 Hours)**

Attack, Support, Check, Check-Mate, Stale-Mate, Exchange of pieces, Revision + Remaining Portion, **Three stages-** Opening, Middle game, Endgame

**Unit 3: Opening (5 Hours)**

Basic rules of development, Types of openings

**Unit 4: Basic elementary mates (5 Hours)**

The Queen mate, The two rooks mate, The one rook mate, Challenging problems, The double bishops mate, The bishop & knight mate

**Unit 5: Middle game (5 Hours)**

**Themes -** Pin, Fork, Double Attack, Back Rank, Discovered Attack, Discovered Check, Passed Pawn, under promotion, Smothered Mate, Destroying the defender.

**Unit 6: Endgame (5 Hours)**

King Pawn ending, Rook pawn ending, Selected games of great players, Tournament (Playing Practise)

**Course Outcomes:**

The student will be able to –

1. Improve concentration, planning, calculations and management skills (management skills includes time management as well as resource management)
2. Calculate at least next 3 to 4 moves at the time of playing a game
3. Solve all types of checkmates (1 Queen, 2 Rooks, 1 Rook, and 2 Bishops)
4. know all types of themes that are used in chess.
5. Participate in the chess tournament and can score very well.



**Course Name: Drawing and Painting**

**Course Code: GP104L**

**Course Type: L**

**Credits: 1**

**Teaching Scheme: Lab: 02 Hours / Week**

**Unit 1: Elements of Art**

**(5 Hours)**

Introduction to art media and its applications- different art media- pencils, color pencil, crayons, poster, erasers, acrylic, rendering, and shedding skills

**Unit 2: 2D and 3D design**

**(5 Hours)**

Introduction to basic sketching techniques- drawing with different sketching techniques, freehand sketching of objects of day –to - day life

**Unit 3: Color theory**

**(5 Hours)**

Introduction to color painting and color theory- color schemes

**Unit 4: Figure drawing**

**(5 Hours)**

Figure drawing –Human proportion and figure construction, study of bone and muscle structure

**Unit 5: Art History**

**(5 Hours)**

Prehistoric to Renaissance, Renaissance to modern art

**Unit 6: Graphics Design**

**(5 Hours)**

Graphics Design process of visual communication and more of typography, photography and illustration

**Text Books:**

1. *“Contemporary Indian art other realities” Yashodhara Dalmia, Marg Publications.*
2. *“Contemporary art in India- A perspective” Pran Nathmago, National book trust India*
3. *“Contemporary art in Baroda” G. M. Shaikh, Tulika books Delhi*
4. *“Color Theory”, J. J. Jagtap, Jagtap Publishing House Pune.*
5. *“Visual Art”, J. J. Jagtap, Jagtap Publishing House Pune.*

**Course Outcomes:**

The student will be able to –

1. Understand fundamental of visual art, colour study, human proportion etc
2. Enable student to enhance their practical skills
3. Facilitate awareness of current trend and movement in the field of visual art
4. To cultivate good communication skills and appreciation of work.
5. Develop leadership competency qualities among follow binges.
6. Provide interdisciplinary approach in visual art.

**Course Name: Flute**

**Course Code: GP105L**

**Course Type: L**

**Credits: 1**

**Teaching Scheme: Lab: 02 Hours / Week**

**Unit 1 :** (5 Hours)

Introduction with Flute & Flute Parts, Basic Finger Movement Exercises

**Unit 2 :** (5 Hours)

Theory of Swaras & Ragas and Basic Element of Music, Prepare Alankaras & Dhuns

**Unit 3 :** (5 Hours)

Small lead tunes with finger exercises

**Unit 4 :** (5 Hours)

Introduction of Saptak, Komal and Trivra Swaras

**Unit 5 :** (5 Hours)

Full length lead Songs

**Unit 6 :** (5 Hours)

Basic Dhun Patterns and few songs

**Course outcome :**

After successful completion of course Students will be able to:

1. Knowledge of basic Theory of Flute & Music and Best Finger movements on flute.
2. Knowledge of Swaras & Ragas and also know relationship between them. Able to play Sargams, Dhuns, and songs.
3. Play any lead song with the help of Notation.
4. Able to recognize the knowledge of swaras in every Saptak. (Shudha, Komal and Trivra Swaras)
5. Able to play full length lead Songs on flute
6. Able to accompaniment for any song with Different rhythm patterns.

**Course Name: Guitar**

**Course Code: GP106L**

**Course Type: L**

**Credits: 1**

**Teaching Scheme: Lab: 02 Hours / Week**

**Unit 1 :** (4 Hours)

Introduction of guitar and its parts, basic finger movement exercises

**Unit 2 :** (4 Hours)

Advance figure movements exercises and small tunes

**Unit 3 :** (6 Hours)

Introduction of scale and it's positions

**Unit 4 :** (6 Hours)

Long length songs and introduction of chords

**Unit 5 :** (6 Hours)

How to construct the chords form scale

**Unit 6 :** (5 Hours)

Recognize the notes, chords of the song and play notes, chords of the songs by different strumming patterns

**Course outcome :**

After successful completion of course Students will be able to:

1. Identify different parts of guitar
2. Recognize different scale of music for guitar
3. Play the skills and identify notes and scales for song
4. Demonstrate the chords based on scales
5. Play chords and rhythm pattern on guitar
6. Accompany and play complete song on guitar by using chords and scales

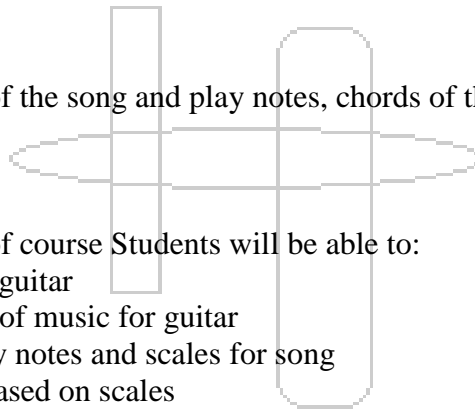

**Course Name: Photography**

**Course Code: GP108L**

**Course Type: L**

**Credits: 1**

**Teaching Scheme: Lab: 02 Hours / Week**

**Unit 1: Introduction and history of Photography (4 Hours)**

**Introduction:** Course Syllabus discussion, Overall roadmap, grading criteria

**History of Photography:** Camera, Black and white film, Colored images, Milestones in photography

**Unit 2: Creative Camera modes (4 Hours)**

Exposure, Automatic Modes, Semi-Automatic Modes and Fully Manual Mode

**Unit 3: Basic techniques and knowledge of Compositional aspects (4 Hours)**

Composition elements, rules, dos and don'ts, Subject placement, Setting up the camera angle to create different meaning and tone of the photograph captured

**Unit 4: Aesthetics (6 Hours)**

Perspective creation and distortion, Theme based photography, Creating intentional blurred images

**Unit 5: Digital Knowhow (6 Hours)**

Introduction to Digital Sensor, Image Sharpness, Histogram, High Dynamic Range (HDR) imaging

**Unit 6: Field Assignments (6 Hours)**

Practicing various techniques to create good photographs based upon the covered tricks and techniques

**Course Outcomes:**

The student will be able to –

1. Handle digital camera confidently
2. Use different camera modes and also understand the difference between these modes
3. Capture photograph with different composition techniques
4. Put desired aesthetic sense and effects in the created photograph
5. Convey the story through photograph
6. Understand different types of digital cameras and basic digital sensor technology

**Course Name: Tabla**

**Course Code: GP109L**

**Course Type: L**

**Credits: 1**

**Teaching Scheme: Lab: 02 Hours / Week**

**Unit 1:** (5 Hours)  
Tabla and Rhythm Introduction

**Unit 2:** (5 Hours)  
Playing basic tukda

**Unit 3:** (5 Hours)  
Padhant tukda

**Unit 4:** (5 Hours)  
Taal Introduction

**Unit 5:** (5 Hours)  
Padhan Teen Taal

**Unit 6:** (5 Hours)  
Playing Teen Taal with Padhan

**Text Books:**

1. *Tabla Guide*

**Course Outcomes:**

The student will be able to –

1. Identify the various components of Tabla and know the beats
2. Know the language of Tabla
3. Understand how to utter the padhan
4. Know about the taal
5. Know about taal with padhan
6. Know about the basic performance about taal and tukada

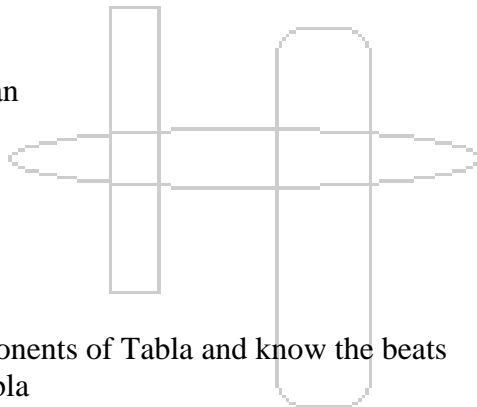

**Course Name: Taekwondo**

**Course Code: GP110L**

**Course Type: L**

**Credits: 1**

**Teaching Scheme: Lab: 02 Hours / Week**

**Unit 1: Basic Stance (5 Hours)**

Introduction of Stances, Type of stance, Use of Stance,etc.

**Unit 2: Basic Blocks (5 Hours)**

Introduction of Blocks, Type of Blocks, Use of Blocks,etc.

**Unit 3: Basic Kicks (5 hours)**

Introduction of Kicks, Type of Kicks, Use of Kicks,etc.

**Unit 4: Combination of Blocks & Kicks (5 hours)**

Combination of various Blocks & Kicks together

**Unit 5: Taekwondo Sparring (5 hours)**

Professional Taekwondo Fight

**Unit 6: Self Defense Techniques (5 hours)**

Wrist Grab, Shirt Grab, Defense from Punch & Kick, Headlock, Bear Hug from Behind or Front, Two Attackers, etc.

**Course Outcomes:**

The student will be able to –

1. Demonstrate and identify different basic stances
2. Demonstrate and identify different blocks and to use them
3. Demonstrate and identify different kicks
4. Demonstrate Sparring Stance and variety of kicks and double or even triple kicks can be performed in quick succession.
5. Engage and attempt to best each other in a controlled form of mock combat or fight.
6. Demonstrate certain self defence techniques like wrist grab, headlock etc.

**Course Name: Vocal**

**Course Code: GP111L**

**Course Type: L**

**Credits: 1**

**Teaching Scheme: Lab: 02 Hours / Week**

**Unit 1:** (5 Hours)  
Introduction of basic vocal music

**Unit 2:** (5 Hours)  
Basic knowledge of Swaras

**Unit 3:** (5 Hours)  
Basic swara Alankar or Sargam. One song

**Unit 4:** (5 Hours)  
raag yaman and one song based on it

**Unit 5:** (5 Hours)  
Raag sarang and bhimplas and one song based on them

**Unit 6:** (5 Hours)  
Different types of music, difference between classical and light music, bhajan, gazhal, duet song, etc.

**Course Outcomes:**

The student will be able to

1. To know what is vocal music
2. Sing basic swaras
3. Sing & knowledge of swaralankar
4. knowledge of Raag Yaman
5. knowledge of Raag Sarang & Bhimpalas
6. knowledge & sing different music such as Bhajan, Gazal, Duet song etc.

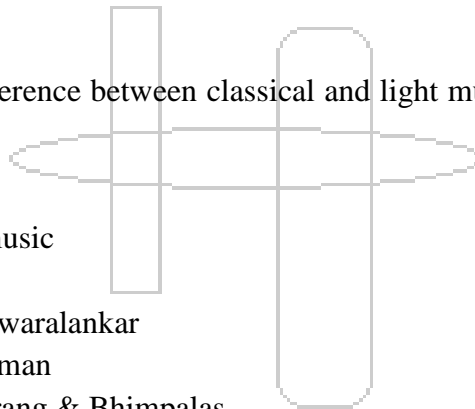

**Course Name: Yoga and Pranayam**

**Course Code: GP112L**

**Course Type: L**

**Credits: 1**

**Teaching Scheme: Lab: 02 Hours / Week**

**Unit 1: Breathing exercises**

**(5 Hours)**

Various types of “Pranayam” like Bhasrika, Anulom-Vilom, Sooryabhyas, Chandrabhyas, Kapalbhata, Shwasawarodh, Bhramari

**Unit 2: Omkar Sadhana**

**(5 Hours)**

Breaking down of Omkar into Akar, Ukar and Makar. Chanting of all these. Chanting of the whole Omkar. Mudra Pranayam (6 types), Group Omkar.

**Unit 3: Yogasan**

**(5 Hours)**

Yogasanas in different postures- while lying down on back, while lying down on stomach, while standing up, while sitting down. Correct postures of all Yogasanas and their benefits.

**Unit 4: Sooryanamaskar**

**(5 Hours)**

Correct method of performing the sun salutations and their benefits.

**Unit 5: Sooryanamaskar with Pranayam**

**(5 Hours)**

Correct method of performing the sun salutations coupled with Pranayam and their benefits.

**Unit 6: Guided Meditation and Yoganidra**

**(5 Hours)**

Guided Meditation for positive thinking and Yoganidra for a relaxed body and mind.

**Course Outcomes:**

The student will be able to –

1. Perform various types of Pranayam like Nadishodhan, Sooryabhyas, Chandrabhyas, Bhasrika, Rapid inhalation and exhalation and various types of Mudra Pranayam.
2. Chant “Omkar” in its root form as well as modified form. Students shall be able to feel the positive vibrations created by correct chanting of “Omkar”.
3. Perform various yogasans in their correct posture form and experience their benefits towards health, body posture and flexibility.
4. Demonstrate scientifically correct Sun Salutations i.e Sooryanamaskars and reap its benefits.
5. Harmonise Sooryanamaskars alongwith Pranayam and energies themselves.
6. Relax their body and mind through guided Meditation and Yoganidra helping thereby to calm down, channelize their energy in the right manner and concentrate better.



**Course Name: Film Appreciation**

**Course Code: GP115L**

**Course Type: L**

**Credits: 1**

**Teaching Scheme: Lab: 02 Hours / Week**

**Unit 1: The Purposes & Development of Art (5 Hours)**

What is it? Why we create? Prehistoric – Paleolithic art forms, Art in daily lives – Designs for better livelihood, Birth of architecture and sculpture, Rules of Aesthetics in Painting, Architecture and Photography, Basic elements of Art; Colour wheel; Colour Theory; Colour schemes

**Unit 2: Precursors, Birth, and Development of Cinema (5 Hours)**

Story telling through pictures, Magic lantern, Shadow puppets, Birth of Photography, first motion photography and first attempt to film, Narrative based films, Early special effects, Animation and early documentaries, Cinema in twenties and thirties

**Unit 3: Technological developments, World Wars, & Modern Cinema (5 Hours)**

Sound in cinema, Emerging Studio systems around the world and its reparations over cinema, Cinema as political critique of war, Italian Neorealism; depicting Socio-Political-Economical-Cultural situation in Europe, Non-conventional style of Filmmaking, European Art Cinema, French new wave, Cinema around the world

**Unit 4: Cinema of India & Genres in Cinema, in Sixties and Seventies (5 Hours)**

Parallel Cinema movement in India, Genres: Noir, Western, Comedy, Drama, Sci-Fi and Musical, Cinema representing Changing Political Ideologies, Experimentation through Documentaries and non-fiction

**Unit 5: Influences & Contemporary Practices (5 Hours)**

Experimentation in world cinema using other art forms, Non-traditional use of technological and Narrative mediums, Experimentation in Fiction, non-fiction films, Independent cinema; Socio-political and cultural representation through cinema, Influence of Cinema over other audio-visual art forms, Theatre and literature

**Unit 6: Changing media (5 Hours)**

Cinema in 21<sup>st</sup> century, Changing cinema in digital age; new avenues

**Reference Books:**

1. James Monaco, *'How to Read a Film: Movies, Media, and Beyond'* (Fourth Edition), Oxford University Press, 2009
2. Robert Sklar, *'An International History of the Medium'* (Second edition), Pearson, 2001
3. Satyajit Ray, *'Our Films Their Films'* Orient Blackswan Private Limited, 2012

**Course Outcomes:**

The student will be able to –

1. Understand the purpose and development of art in its historical context
2. Understand the development of cinema in its historical context
3. Analyze and interpret framework of cinema
4. Understand the development of language of cinema
5. Have information about the history of cinema
6. Know the experimentation in world cinema and influence of cinema over other art forms

**Course Name: Violin**

**Course Code: GP122L**

**Course Type: L**

**Credits: 1**

**Teaching Scheme: Lab: 02 Hours / Week**

**Unit 1: (4 Hours)**

Introduction of violin, its parts, basic finger movements.

**Unit 2: (4 Hours)**

Introduction of 4 strings. Introduction of scale and different positions.

**Unit 3: (4 Hours)**

Introduction of basic sargam on all strings.

**Unit 4: (6 Hours)**

Advance finger movement

**Unit 5: (6 Hours)**

Sargam with Tabla.

**Unit 6: (6 Hours)**

Introduction of raag Bhoop.

**Course Outcomes:**

The student will be able to –

1. Identify different parts of violin.
2. Identify different scales.
3. Play the sargam.
4. Skillfully manage the bow and fingers simultaneously.
5. Play along with tabla.
6. Perform raag Bhoop with alaap

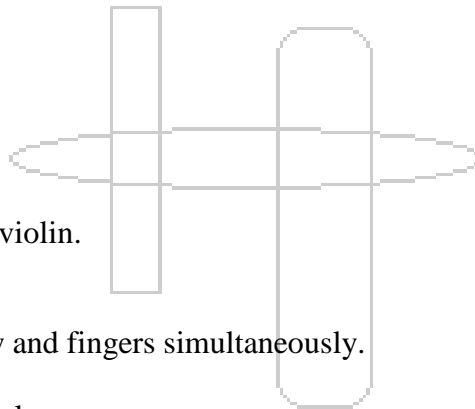

**Course Name: Health Awareness and Monitoring**

**Course Code: GP123L**

**Course Type: L**

**Credits: 1**

**Teaching Scheme: Lab: 02 Hours / Week**

**Unit 1: (4 Hours)**

Introduction of Health & Need of Global awareness.

**Unit 2: (6 Hours)**

Basics of Human Anatomy & Physiology

**Unit 3: (4 Hours)**

Preventive & Social Medicines

**Unit 4: (6 Hours)**

Basics of Diseases, Medicines

**Unit 5: (4 Hours)**

GMP & Manufacturing of Medicines.

**Unit 6: (4 Hours)**

Lifestyle Disorders, Alternative Medicines & Yoga

**Course Outcomes:**

The student will be able to –

1. Know basic of health, current scenario and need
2. Know about human body mechanism
3. Understand basics of social health
4. Vital signs, Parameters, Measuring Aids & Instruments, First aid and basic emergency management.
5. Manufacturing processes,
6. Know strength of indigenous systems to prevent diseases, students can research and find mechanical solutions & instrumentization for these branches.