

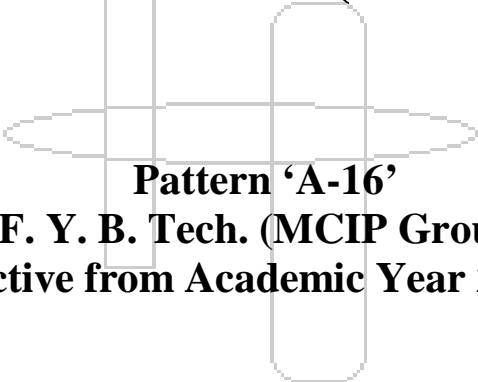

Bansilal Ramnath Agarwal Charitable Trust's
Vishwakarma Institute of Technology
(An Autonomous Institute affiliated to Savitribai Phule Pune University)

Structure & Syllabus of
Department of Engineering, Sciences &
Humanities (DESH)



Pattern 'A-16'
F. Y. B. Tech. (MCIP Group)
Effective from Academic Year 2016-17

Prepared by: - Board of Studies in Engineering, Sciences & Humanities

Approved by: - Academic Board, Vishwakarma Institute of Technology, Pune

Signed by,

Chairman – BOS

Chairman – Academic Board

Content

Sr. No.	Title			Page No.
	Program Outcomes			3
	Course Structure – Core Module and Interdisciplinary Module			4
	Course Syllabi for courses - Core Module			
1	THT	ES151	Differential and Integral Calculus	6
2	THL	ES153	Applied Mechanics	8
3	THL	ES154	Applied Chemistry	11
4	TH	ME151	Thermodynamics	14
5	TH	EC151	Electronics Technology	15
6	TH	HS152	Behavioral Sciences	17
7	LTH	ME152	Engineering Graphics	18
	Course Syllabi for courses – Interdisciplinary Module			
8	THT	ES152	Linear Algebra	20
9	THL	CS151	Fundamentals of Programming	22
10	THL	ES155	Electrical Technology	24
11	THL	ES156	Engineering Physics	26
12	TH	HS151	Indian Philosophy and Ethics	30
13	LTH	HS1XX	International Language	
		HS102	German	32
		HS105	French	34
	Courses to be offered in Semester I only			
14	LTH	HS153	Soft Skills	36
15	L	ME153	Manufacturing Workshop	38
16	AU	ES157	Fundamental Mathematics	39
17	AU	HS101	English	40
18	AU	HS155	Environmental Science	42
	Courses to be offered in Semester II only			
19	L	ME154	Machining Workshop	44
20	L	HS154	General Seminar	45
	General Proficiency Courses			47
	Academic Information – Please visit www.vit.edu			

Program Outcomes

- 1. Engineering knowledge:** Apply the knowledge of mathematics, science, engineering fundamentals, and an engineering specialization to the solution of complex engineering problems.
- 2. Problem analysis:** Identify, formulate, review research literature, and analyze complex engineering problems reaching substantiated conclusions using first principles of mathematics, natural sciences, and engineering sciences.
- 3. Design/development of solutions:** Design solutions for complex engineering problems and design system components or processes that meet the specified needs with appropriate consideration for the public health and safety, and the cultural, societal, and environmental considerations.
- 4. Conduct investigations of complex problems:** Use research-based knowledge and research methods including design of experiments, analysis and interpretation of data, and synthesis of the information to provide valid conclusions.
- 5. Modern tool usage:** Create, select, and apply appropriate techniques, resources, and modern engineering and IT tools including prediction and modeling to complex engineering activities with an understanding of the limitations.
- 6. The engineer and society:** Apply reasoning informed by the contextual knowledge to assess societal, health, safety, legal and cultural issues and the consequent responsibilities relevant to the professional engineering practice.
- 7. Environment and sustainability:** Understand the impact of the professional engineering solutions in societal and environmental contexts, and demonstrate the knowledge of, and need for sustainable development.
- 8. Ethics:** Apply ethical principles and commit to professional ethics and responsibilities and norms of the engineering practice.
- 9. Individual and team work:** Function effectively as an individual, and as a member or leader in diverse teams, and in multidisciplinary settings.
- 10. Communication:** Communicate effectively on complex engineering activities with the engineering community and with society at large, such as, being able to comprehend and write effective reports and design documentation, make effective presentations, and give and receive clear instructions.
- 11. Project management and finance:** Demonstrate knowledge and understanding of the engineering and management principles and apply these to one's own work, as a member and leader in a team, to manage projects and in multidisciplinary environments.
- 12. Life-long learning:** Recognize the need for, and have the preparation and ability to engage in independent and life-long learning in the broadest context of technological change.

F.Y. B. Tech. Structure for MCIP Group : Core Module Semester I and Semester II

FF No. 653

Course Code	Course Type	Course Name	Teaching Learning Scheme					Assessment Scheme (100 mark scale)				
			Th	Lab	Tut	Hrs. / Week	Credits	ISA – 100 marks converted to 30			MSE (20)	ESE (100 marks converted to 50)
								CA	MSA	ESA		
Common for Semester I and Semester II												
ES151	THT	Differential and Integral Calculus	2	0	1	3	3	30	20	50	20	100
ES153	THL	Applied Mechanics	3	2	0	5	4	30	20	50	20	100
ES154	THL	Applied Chemistry	2	2	0	4	3	30	20	50	20	100
ME151	TH	Thermodynamics	2	0	0	2	2	30	20	50	20	100
EC151	TH	Electronics Technology	2	0	0	2	2	30	20	50	--	--
HS152	TH	Behavioral Sciences	2	0	0	2	2	30	20	50	--	--
ME152	LTH	Engineering Graphics	3	4	0	7	5	30	20	50	--	--
GP1XX	L	General Proficiency	0	2	0	2	1	30	20	50	--	--
Common Total			16	10	1	27	22	--	--	--	--	--
Courses to be offered in Semester I only												
HS153	LTH	Soft Skills	1	2	0	3	2	30	20	50	--	--
ME153	L	Manufacturing Workshop	0	2	0	2	1	30	20	50	--	--
ES157	AU	Fundamental Mathematics						30	20	50	--	--
HS101	AU	English	2	0	0	2	Audit	30	20	50		
HS155	AU	Environmental Science						30	20	50	--	--
Grand Total (Semester I)			19	14	1	34	25	--	--	--	--	--
Courses to be offered in Semester II only												
ME154	L	Machining Workshop	0	2	0	2	1	30	20	50	--	--
HS154	L	General Seminar	0	2	0	2	1	30	20	50	--	--
ES158	L	Mini Project	0	4	0	4	2	30	20	50	--	--
Grand Total (Semester II)			16	18	1	35	26	--	--	--	--	--

F.Y. B. Tech. Structure for MCIP Group : Interdisciplinary Module Semester I and Semester II

FF No. 653

Course Code	Course Type	Course Name	Teaching Learning Scheme					Assessment Scheme (100 mark scale)					
			Th	Lab	Tut	Hrs. / Week	Credits	ISA – 100 marks converted to 30			MSE (20)	ESE (100 marks converted to 50)	
								CA	MSA	ESA			
Common for Semester I and Semester II													
ES152	THT	Linear Algebra	2	0	1	3	3	30	20	50	20	100	
CS151	THL	Fundamentals of Programming	2	4	0	6	4	30	20	50	20	100	
ES155	THL	Electrical Technology	3	2	0	5	4	30	20	50	20	100	
ES156	THL	Engineering Physics	3	2	0	5	4	30	20	50	20	100	
HS151	TH	Indian Philosophy and Ethics	2	0	0	2	2	30	20	50	--	--	
HS1XX	LTH	International Language	2	2	0	4	3	30	20	50	--	--	
GP1XX	L	General Proficiency	0	2	0	2	1	30	20	50	--	--	
Common Total			14	12	1	27	21	--	--	--	--	--	
Courses to be offered in Semester I only													
HS153	LTH	Soft Skills	1	2	0	3	2	30	20	50	--	--	
ME153	L	Manufacturing Workshop	0	2	0	2	1	30	20	50	--	--	
ES157	AU	Fundamental Mathematics	2	0	0	2	Audit	30	20	50	--	--	
HS101	AU	English						30	20	50	--	--	
HS155	AU	Environmental Science						30	20	50	--	--	
Grand Total (Semester I)			17	16	1	34	24	--	--	--	--	--	
Courses to be offered in Semester II only													
ME154	L	Machining Workshop	0	2	0	2	1	30	20	50	--	--	
HS154	L	General Seminar	0	2	0	2	1	30	20	50	--	--	
ES158	L	Mini Project	0	4	0	4	2	30	20	50	--	--	
Grand Total (Semester II)			14	20	1	35	25	--	--	--	--	--	

General Proficiency Courses [Please see Annexure I]

Course Name: Differential and Integral Calculus

Course Code: ES151

Course Type: THT

Credits:3

**Teaching Scheme: Theory : 2 Hours / Week
Tut : 1 Hours / Week**

Unit I: Infinite Series (5 Hours)

Sequence and infinite series, test of convergence, power series, region of convergence, Taylor and Maclaurin's series and Taylor Theorem.

Unit II: Partial Differentiation (5 Hou

Introduction to functions of two or more variables, introduction to curves and surfaces, limits and continuity, Partial derivatives, chain rules , derivative of implicit function.

Unit III: Applications of partial differentiation (5 Hours)

Homogeneous functions, Euler's theorem, Jacobian, maxima and minima of functions of two variables, Method of Lagrange's multipliers.

Unit IV: Integral Calculus (5 Hours)

Beta and Gamma function, Differentiation under integral sign, Error function.

Unit V: Ordinary differential equations (5 Hours)

Introduction to first order differential equations, modeling, geometric interpretation of solution, exact and linear differential equation.

Unit VI: Partial differential equations (5 Hours)

Introduction to partial differential equations, classification, solution of PDE by variable separation method, first order linear partial differential equations

List of Tutorials:

Tutorial Number	Topic	Mode of Conduct
1	Infinite series, test of convergence, power series, region of convergence	<ul style="list-style-type: none"> • Instructions • Problem solving • Home Assignment
2	Taylor and Maclaurin's series and Taylor Theorem.	<ul style="list-style-type: none"> • Problem Solving • Group Project • Home Assignment
3	Introduction to curves and surfaces, Partial derivatives	<ul style="list-style-type: none"> • Problem Solving • Demonstration on curves and surfaces • Home Assignment
4	Chain rules , derivative of implicit function.	<ul style="list-style-type: none"> • Problem Solving • Home Assignment
5	Homogeneous functions, Euler's theorem, Jacobian,	<ul style="list-style-type: none"> • Problem Solving • Home Assignment
6	maxima and minima of functions of two variables, Method of	<ul style="list-style-type: none"> • Problem Solving • Group Project

	Lagrange's multipliers.	<ul style="list-style-type: none"> • Home Assignment
7	Mid semester assessment	<ul style="list-style-type: none"> • Viva/MCQ test/Quiz
8	Beta and Gamma function	<ul style="list-style-type: none"> • Problem Solving • Home Assignment
9	Differentiation under integral sign, Error function.	<ul style="list-style-type: none"> • Problem Solving • Home Assignment
10	Modeling, geometric interpretation of solution	<ul style="list-style-type: none"> • Problem solving • Home Assignment
11	Exact and linear differential equation.	<ul style="list-style-type: none"> • Problem solving • Group Project(Applications) • Home Assignment
12	Partial differential equations classification, solution of PDE by variable separation method	<ul style="list-style-type: none"> • Problem Solving • Group Project(Applications) • Home Assignment
13	first order linear partial differential equations	<ul style="list-style-type: none"> • Problem Solving • Home Assignment
14	End semester assessment	<ul style="list-style-type: none"> • Viva/MCQ test/Quiz

Text Books:

1. Thomas G. B. and Finney, 'Calculus and analytic Geometry', 11th Edition, Pearson Publications
2. Ramana B. V., 'Higher Engineering Mathematics' 5th Reprin, Tata McGraw Hill publishing company ltd.

Reference Books:

1. Ron Larson and Bruce H. Edwards, 'Text book of Calculus', Brooke/Cole, a part of engage Learning (Indian Edition), (c) 2011.
2. Murray R. Spiegel, 'Advanced Calculus', Schaum's out line series, New Delhi, 1st Edition, 1981, McGraw Hill International Book Co.
3. Tom Apostol, 'Calculus', volume-II, 2nd Edition, Wiley India Edition
4. Erwin Kreyszig, 'Advanced Engineering Mathematics' 10th Edition, Dec. 2010, , John Wiley and sons, Inc

Course Outcomes:

The student will be able to –

1. acquire the knowledge of infinite series, partial differentiation, curves and surfaces, methods of integration
2. apply the knowledge of partial derivative to find maxima and minima of functions of two variables, derivatives of homogeneous functions, special functions in solving improper integrals
3. interpret and analyze properties of jacobians, solutions of ODE and PDE
4. Demonstrate the chain rules of Partial derivative, the power series of function and its region of convergence, characterization of PDE, solutions of PDE.
5. Set up, solve and analyze ordinary and partial differential equations

Course Name: Applied Mechanics

Course Code: ES153

Course Type: THL

Credits:4

**Teaching Scheme: Theory : 3 Hours / Week
Lab : 2 Hours / Week**

Unit I: Basics of Statics: (7 Hours)

Review: Types of Mechanics, historical development, idealization, SI units, prefixes & their conversions, scope of study, Definition of force, surface forces, body forces, internal and external force, push and pull force, Tension and Compression force.

Various force systems, six fundamental principles of mechanics.

Coplanar Force System: Rectangular & skew resolution of force, composition of forces, resultant and equilibrium of particle, Moment of force, Varignon's theorem, couple, and equivalent force couple system,

Application to find resultant of: concurrent, parallel and non concurrent non parallel force system.

Unit II: Non-coplanar Force System: (6 Hours)

Vector representation of force, rectangular components of a force, direction angles, direction cosines, unit vector, position vector, dot product and cross product, types of supports and support reactions. Moment of force about a point & about an axis, Resultant and equilibrium of concurrent, parallel & general force systems,

Unit III: Equilibrium of Rigid Bodies: (7 Hours)

Conditions of equilibrium in coplanar and non coplanar force system. Concept of free body diagram, types of supports, loads & beams, Determination of reactions at supports for various types of loads on beams (simply supported, cantilever, compound).

Application of equations of equilibrium to simple frictionless rigid body assemblies.

Unit IV: Distributed Forces: (6 Hours)

Centroid: concept of center of mass, center of gravity & centroid, use of Varignon's theorem of moment, application of standard formulae to find centroid of composite plates and wires, Forces on submerged flat and curved surfaces, centre of pressure.

Moment of Inertia: Concept & its significance, parallel & perpendicular axis theorems, polar moment of inertia, radius of gyration, M.I. of simple and composite areas.

Unit V: Analysis of Structures: (8 Hours)

Plane truss: Concept of plane and space truss, two force and multi force member, perfect, imperfect, deficient, redundant plane truss, assumptions in analysis of truss, method of joints and method of section.

Frames: Analysis of plane frames.

Friction: concept of friction, Coulomb's laws of dry friction, limiting force of friction, coefficient of friction, angle of friction, angle of repose, cone of friction, variation of frictional force for various conditions (no friction, no motion, impending motion and motion conditions), Equilibrium of particle and rigid body assemblies including friction.

Unit VI: Kinematics and Kinetics of a particle: (8 Hours)

Rectilinear motion:

Review : Definition of motion (planar and space), types of motion (translation, rotation, general plane motion). Rectilinear Motion: concept of position, displacement, distance, speed, average & instantaneous velocity and acceleration, uniform motion, uniformly accelerated motion, constant acceleration equations, gravitational motion & its equations.

Variable acceleration: primary and secondary equations of motion, general approach for determination of motion of a particle, application to variable acceleration,

Curvilinear motion: Motion along plane curved path, Concept of position, displacement, distance, speed, average & instantaneous velocity and acceleration, curvature, radius of curvature in curvilinear motion.

Application to find velocity and acceleration in three systems: rectangular coordinate (x-y), normal and tangential (n-t), radial and transverse (r- θ).

Force and acceleration: introduction to kinetics, Newton's second law of motion, D'Alembert's principle (dynamic equilibrium), concept of FBDE, working concept of application of $F = ma$ in curvilinear motion in vertical and horizontal plane followed by numerical on (i) Rectangular components (ii) tangential and normal components

List of Practical's / Activities:

Sr. No.	Practical/Activity
1	Introduction of activities, use of calculator, revision of numerical based on prerequisite
2	Practical:- <ul style="list-style-type: none"> • Equilibrium of coplanar concurrent force system. • Application of law of moment using bell crank lever/ F- frame.
3	Practical:- <ul style="list-style-type: none"> • Equilibrium of concurrent space force system • Equilibrium of parallel space force system
4	Practical:- <ul style="list-style-type: none"> • To find support reaction in (i) simple beams, (ii) compound beams.
5	Activity:- <ul style="list-style-type: none"> • Course project: (Group activity: group of 3 to 5 students) Student has to complete course project on ideas concern to the subject but not limited to, it may be Animation of mechanisms/computer program to solve numerical/ Modeling of physical system using laws of mechanics/Design new experiment in engineering mechanics/ Poster presentation/ Seminar / Preparation of question bank with solutions(eg. Match the pairs), case studies, technical surveys. <p><i>Note :Completion of assigned (minimum five) problems which will cover syllabus of the respective unit</i></p> <ul style="list-style-type: none"> • Problem solving on coplanar force system.
6	<ul style="list-style-type: none"> • Course project • Problem solving on non coplanar force system.
7	<ul style="list-style-type: none"> • Course project • Problem solving equilibrium of rigid bodies.
8	<ul style="list-style-type: none"> • Course project • Problem solving on centroid, M.I. of simple and composite areas.
9	<ul style="list-style-type: none"> • Course project • Problem solving on analysis of truss ,frames & friction
10	<ul style="list-style-type: none"> • Course project • Problem solving on kinematics and kinetics of a particle.

Text Books:

1. *J. L. Meriam, L. G. Kraige; Engineering Mechanics Statics & Dynamics - 5th edition, John Wiley & Sons, Inc. Publication.*
2. *F. P. Beer and E. R. Johnston; Vector Mechanics for Engineers Statics & Dynamics- 9th edition, Tata McGraw-Hill Publications.*

Reference Books:

1. *E.W. Nelson; Schaum's Outlines : Engineering Mechanics Statics & Dynamics, McGraw-Hill Publications.*
2. *R. C. Hibbeler; Engineering Mechanics Statics & Dynamics, Pearson Publication.*

Course Outcomes:

After successful completion of this course, students will be able to

1. Evaluate resultant, moment of force and apply equilibrium equations to coplanar force system.
2. Determine resultant, moment of force and apply equilibrium equations for non-coplanar force system.
3. Apply equilibrium equations to beams and simple frictionless rigid body assemblies.
4. Determine the centroid and second moment of area of simple and composite lamina.
5. Analyze co-planar systems of forces to determine the forces in members of trusses, frames and assemblies including friction.
6. Analysis of motion of the particle along rectilinear and curved path and application of Newton's second law of motion using different coordinate systems.

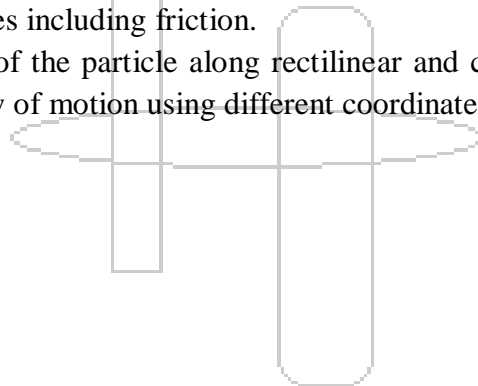

Course Name: Applied Chemistry

Course Code: ES154

Course Type: THL

Credits:3

Teaching Scheme: Theory : 2 Hours / Week
Lab : 2 Hours / Week

Unit I: Water **(6 Hours)**

[A] Delivery Content: Introduction, Chemical Analysis of Water – Hardness; Temporary and Permanent, Alkalinity; Hydroxide, Carbonate and Bicarbonate, Softening Methods – Zeolite or Permutit Process, Ion Exchange or Deionization or Demineralization Process, Water Purification by Reverse Osmosis, Water Filtration by Electro dialysis, Numerical on water Treatment - Zeolite Process, Hardness Determination and Alkalinity Calculation

[B] Learner's Activity: Determination of BOD, COD, DO and TDS – Procedure, Observations and Calculations

Unit II: Molecular Spectroscopy **(7 Hours)**

[A] Delivery Content: Law of Absorption - Lambert's Law and Beer's Law, Integrated Equation, Principle, Theory, Instrumentation and Working of Ultra Violet - Visible Spectrophotometer, Applications of UV – Vis Spectroscopy, Woodward Fieser Rules for Calculating λ_{max} in Conjugated Dienes and α, β - Unsaturated Carbonyl Compounds - Problems, Principle, Theory, Instrumentation and Working of Infra-Red Spectrophotometer, Applications of IR Spectroscopy, Problems, Principle, Theory, Instrumentation and Working of Nuclear Magnetic Resonance Spectrophotometer, Applications of NMR Spectroscopy, Problems

[B] Learner's Activity: Additional Problems on Woodward Fieser Rules, UV – Vis, IR and NMR Spectroscopy

Unit III: Separation Techniques **(6 Hours)**

[A] Delivery Content: Introduction, Principle, Types and Classification of Chromatographic Techniques, Thin Layer Chromatography – Principle, Theory, Working and Applications, Paper Chromatography – Principle, Theory, Working and Applications, Column Chromatography (Passing Reference), High-Performance Liquid Chromatography – Principle, Theory of HPLC, Instrumentation and Working, Applications of HPLC, Gas Chromatography – Principle, Theory of GC, Instrumentation, Working and Applications of GC

[B] Learner's Activity: Ion Exchange Chromatography – Principle, Theory, Instrumentation, Working and Applications

Unit IV: Fuel and Combustion **(5 Hours)**

[A] Delivery Content: Types of calorific value, Proximate analysis of coal, Ultimate analysis of coal, Numerical on analysis of coal, Refining of petroleum, Combustion- Theoretical Air requirement, Theoretical Oxygen Requirement of solid fuels, Theoretical Oxygen Requirement of Liquid /Gaseous fuels, Numerical on combustion

[B] Learner's Activity: Power alcohol, Biodiesel and Rocket Propellants

Unit V: Corrosion **(3 Hours)**

[A] Delivery Content: Mechanism of corrosion: Wet (Hydrogen evolution and Oxygen absorption), Methods of prevention of corrosion, cathodic protection, Anodic protection, Surface Conversion Coatings (Metallic – Electroplating by Hot Dipping), Factors affecting rate of corrosion

[B] Learner's Activity: Applications of Electroplating

Unit VI: Alloys

(3 Hours)

[A] Delivery Content: Introduction, Types / Classification of Alloys, Alloys of Copper (Brass, Bronze and Gun metal), Properties and methods of preparation of Alloys

[B] Learner's Activity: Treatment of Alloys

List of Practical:

One Experiment on each unit and Course Project (In a group of maximum five students)

1. Determination of total hardness by EDTA method.
2. Determination of alkalinity of water.
3. Experimental verification of Beer-Lambert's law by determining unknown concentration of solution of ferric ammonium sulphate using colorimeter.
4. Separation of mixture of ortho and para nitro aniline by Thin Layer Chromatography.
5. Separation and identification of components of mixture by paper chromatography.
6. Separation and identification of metal ions from binary mixture of cations using column chromatography.
7. Demonstration of IEC, HPLC and GC Chromatograms.
8. Determination of ash and moisture from coal (Proximate Analysis).
9. Estimation of rate of corrosion of galvanized iron plates in acidic and basic medium.
10. Application of nickel coating on copper metal using electroplating method.
11. Estimation of Copper from brass iodometrically.

Text Books:

1. *Dr. Sunita Rattan; A Textbook of Engineering Chemistry; Third Edition, S. K. Kataria & Sons, New Delhi, 2012*
2. *P.C. Jain and Dr. Monika Jain; Engineering Chemistry; Sixteenth Edition, Dhanpat Rai Publishing Company(P) Ltd., New Delhi, 2013*
3. *Dr. Sunita Rattan, Experiments in Applied Chemistry; Third Edition, S. K. Kataria & Sons, New Delhi, 2012*
4. *S. K. Bhasin and Sudha Rani; Laboratory Manual on Engineering Chemistry; Third Edition, Dhanpat Rai Publishing Company (P) Ltd., New Delhi, 2012*

Reference Books:

1. *A. K. De; Environmental Chemistry; Eighth Edition, John Wiley and Inc., 1999*
2. *D. A. Skoog and J. J. Leary; Principles of Instrumental Analysis; Fourth Edition, Saunders College Publishing, 1992*
3. *A.K.Shaha; Combustion Engineering and Fuel Technology; Edition Oxford & IBH Publishing Company*
4. *Svehla G. and Sivasankar B.; Vogel's Quantitative Inorganic Analysis; Seventh Edition, Pearson Education, 2012*
5. *J. Mendham and R. C. Denney and J. D. Barnes and M. J. K. Thomas; Vogel's Text Book of Quantitative Chemical Analysis; Sixth Edition, Pearson Education Limited, 2012*

Course Outcomes:

Learner will be able to

1. Analyze, treat and determine the impurities in domestic and industrial waste water.
2. Apply the principles of different spectroscopic methods and find out the unknown concentration of given solution of complex compound by Colorimetry.
3. Understand the basics of different chromatographic techniques Separate and identify the components in the given mixture from retardation / retention factor

4. Apply appropriate logic, Solve problems and arrive at solution based on water treatment, spectroscopic principles, chromatographic techniques, grading of fuels (from the results of proximate analysis).
5. Suggest suitable mechanism for prevention of corrosion of metal and compare the rate of corrosion of metal in acidic and basic media.
6. Suggest suitable method of preparation of alloys and estimate copper from brass iodometrically.

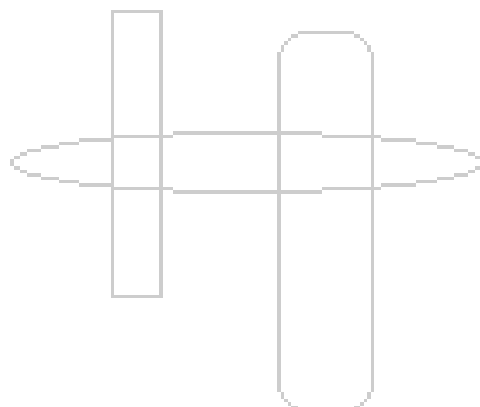

Course Name: Thermodynamics

Course Code: ME151

Course Type: TH

Credits:2

Teaching Scheme: Theory : 2 Hours / Week

Unit I: Fundamentals of thermodynamics (5 Hours)

Thermodynamic systems, properties, processes, macro and microscopic approach, reversible and irreversible processes, Principle of conservation of Mass and Energy, temperature and temperature scale, zeroth law of thermodynamics, Temperature scale numerical.

Unit II: First Law of Thermodynamics and steady flow energy Equations (7 Hours)

Thermodynamic Work, Heat, First law of thermodynamics, Joules experiment, perpetual motion machine I, Limitations of first law of thermodynamics, Application of first law to flow processes, concept of internal energy, flow energy and enthalpy, application of steady flow energy equation to nozzles, turbines, compressors, heat exchanger etc.

Unit III: Ideal Gas Properties and Processes (5 Hours)

Ideal gas properties and gas equations, constant pressure, constant volume, isothermal, adiabatic, polytropic and throttling processes on p-v diagram, heat transfer, work transfer, change in internal energy and enthalpy during these processes.

Unit IV: Properties of Steam (4 Hours)

Formation of steam, phase changes, properties of steam, use of steam tables, dryness fraction and its determination.

Unit V: Vapour Processes (4 Hours)

Non-flow vapour processes - change of properties, work and heat transfer, study of p-v diagram for steam.

Unit VI: Introduction to Power Cycles (3 Hours)

Carnot cycle, Rankine cycle, comparison of Carnot cycle and Rankine cycle.

Text Books:

1. R. K. Rajput, *Engineering Thermodynamics*, Laxmi Publications.
2. P. K. Nag, *Engineering Thermodynamics*, fourth edition, Tata McGraw Hill Publications.

Reference Books:

1. Y. Cengel & Boles: *Thermodynamics – An Engineering Approach*, Tata McGraw Hill Publications.
2. P. L Ballany: *Thermal Engineering*, Khanna Publishers.
3. C.P. Arora: *Engineering Thermodynamics*, Tata McGraw Hill Publications.

Course Outcomes:

The student will be able to –

1. Understand fundamental concepts of thermodynamics.
2. Understand and apply First law of thermodynamics to basic engineering problems.
3. Learn thermodynamic properties and analyze various ideal gas processes.
4. Analyze steam properties using steam table.
5. Understand and analyze various vapour processes.
6. Understand basic power cycles and their comparison.

Course Name: Electronics Technology

Course Code: EC151

Course Type: TH

Credits:2

Teaching Scheme: Theory : 2 Hours / Week

Unit I: Electronic Devices **(5 Hours)**

Diode–Symbol, Structure, Concept of depletion and diffusion layer, forward and reverse diode, Ideal and Practical diode, Zener diode-breakdown, Characteristics; BJT–Symbol, Structure, Common emitter configuration and its biasing, DC load line concept, Characteristics; MOSFET–Symbol, Structure, Characteristics.

Unit II: Logic Gates and Boolean Algebra **(5 Hours)**

Concepts of binary logic, Boolean Algebra, De-Morgan’s Theorem, Simplification of Boolean expressions, Concepts of K-Maps; Logic gates and Truth table, NAND and NOR gate as universal gate; Half Adder, Full Adder.

Unit III: Integrated Circuits **(5 Hours)**

Concept of IC; Types of ICs–SSI, MSI, LSI, VLSI, ULSI; Package type of ICs–Metal CAN, Plastic dual in line, Ceramic flat package; Basics of Op-Amp–Symbol, Parameters; Open loop Op–Amp configurations– Differential Amplifier, Inverting, Non-inverting; Introduction to 555 timer IC.

Unit IV: Analog Communication **(4 Hours)**

Need for analog communication, Communication system, Need for modulation, Types of modulation–AM, FM; Amplitude modulation– Definition, Basic circuit, Spectrum, Bandwidth and applications.

Unit V: Filters **(4 Hours)**

Concept of Fourier series, Concept of spectrum, Concept of Filters , Classification of filters– Passive and Active, AF and RF, Analog and Digital; Comparison of active and passive filters; Circuits for Passive filters, Concept of N^{th} order filter.

Unit VI: Applications of Electronic Circuits **(5 Hours)**

Applications of diode as regulator and rectifier; Application of Transistor as an amplifier; Applications of Op-Amp– adder and comparator; AM using diode; Study of Datasheets– Diode 1N400X, BJT BC548, MOSFET 2N7000, Op-Amp IC741, 555 timer IC, Function Generator IC8038.

Text Books:

1. *Electronic Devices, Thomas L. Floyd, Pearson Education.*
2. *M. Morris Mano, Digital Design - 3rd Edition, Pearson Education.*
3. *Op-amp and Linear Integrated Circuits by Ramakant A. Gayakwad, Prentice-Hall of India pvt.ltd.*
4. *Analog Communication by Louis E. Frenzel, Tata Mc Graw Hill Education pvt.ltd.*

Reference Books:

1. *Electronic Circuits, Analysis and Design by Donald A. Neamen, Tata-Mc Graw Hill Education pvt. ltd.*
2. *Modern Digital Electronics by R. P. Jain, Tata-Mc Graw Hill Education pvt.ltd*

3. *Electronics Devices and Circuits* by J. B. Gupta, S. K. Kataria and Sons Publishing Company.
4. *Digital Logic: Applications and Design*, John M. Yarbrough West Publishing Company, 1997 *Technology and Engineering*.

Course Outcomes:

The student will be able to –

1. Explain the basic concepts and working of electronic devices like diode and BJT.
2. Illustrate the concepts of binary logic and logic gates.
3. Elaborate open loop configurations of integrated circuits.
4. Describe communication system and amplitude modulation technique.
5. Classify electronic filter configurations.
6. Discuss the applications of electronic circuits.

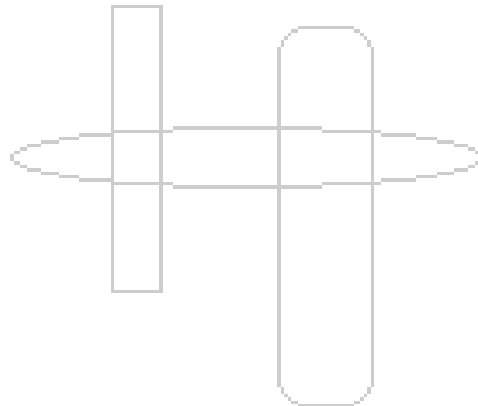

Course Name: Behavioral Sciences

Course Code: HS152

Course Type: TH

Credits:2

Teaching Scheme: Theory : 2 Hours / Week

Unit I: Foundations of Psychology

(4 Hours)

Definition of Psychology; Historical antecedents of Psychology and trends in the 21st century, Psychology and Scientific methods; Psychology in relation to other social sciences and natural, Application of Psychology to societal problems, Various branches of Psychology and its application to society

Unit II: Development of Human Behavior

(6 Hours)

Growth and Development; Principles of Development, Personality; Definition and concept ; Role of genetic and environmental factors in determining human behavior; influence of cultural factors in socialization, Theories of personality(psychoanalytic theory, trait and type approaches), Training for personality development .

Unit III: Family Psychology

(4 Hours)

Concept of family, types of family, Significance of family on the wellbeing of an individual, Types of Conflicts and its consequences

Unit IV: Motivation and Emotion

(6 Hours)

Psychological and physiological basis of motivation and emotion; Measurement of motivation and emotion, Effects of motivation and emotion on behavior, Extrinsic and intrinsic motivation; factors influencing intrinsic motivation, Emotion competence and related issues.

Unit V: Intelligence

(4 Hours)

Concept, definition, history, Theories of Intelligence, Concept of IQ, Aptitude- concept, definition, significance, measurement

Unit VI: Learning

(6 Hours)

Concept, Definition, Components of learning, Methods of learning, Creativity-concept and process, Problem solving techniques

Text Books:

1. *Clifford T. Morgan and Richard A. King; Introduction to Psychology; 7th edition, Tata McGraw Hill Publication*
2. *Robert Feldman; Understanding Psychology; 10th edition, Tata McGraw Hill Publication*

Course Outcomes:

Students will be able to-

1. Understand and apply psychological principles to personal life and will implement the concepts of Psychology in day to day life.
2. Get insight into their own personalities and will be able to develop it under the guidance of various theories.
3. Learn the methods to improve their interfamily relationships.
4. Identify the individual differences in motivation and range of emotion. And demonstrate the application self motivation and emotional regulation.
5. Differentiate between intelligence and aptitude and understand about IQ.
6. Equipped with various learning methodologies and be able to resolve problems with a creative outlook.

Course Name: Engineering Graphics

Course Code: ME152

Course Type: LTH

Credits: 5

**Teaching Scheme: Theory : 3 Hours / Week
Lab : 4 Hours / Week**

Unit 1: Orthographic Projections (8 Hours)

Reference Planes, Types and Methods of projections with symbols, Projections of various objects, Various types of sectional views

Unit 2: Isometric Drawing (8 Hours)

Types of pictorial projections, isometric Projections and Isometric views, Construction of Isometric views from given orthographic views.

Unit 3: Projections of points, lines and planes (8 Hours)

Projections of points in various quadrants, Projections of lines inclined to both reference planes (lines in first quadrant only), locating traces of lines. Projections of planes inclined to both reference planes. Projections using auxiliary planes

Unit 4: Projections of Solids (6 Hours)

Classification of solids, Projections of solids such as Prism, Pyramid, Cylinder, Cone, Cube, tetrahedron inclined to both reference planes

Unit 5: Sections of Solids (5 Hours)

Types of section planes, Projections of above solids cut by various section planes, True shape of section.

Unit 6: Development of Lateral Surfaces and Machine Drawing Conventions (7 Hours)

Development of Lateral Surfaces of cones and pyramids - concept, methods, applications
Conventions of machine elements like screw thread, springs, gears, bearings etc.

List of Practical:

- 1. Introduction to Lines, Lettering and Dimensioning (2 Sessions)**
Demonstration of various drawing tools, Learning and using BIS standards of lettering, lines, dimensioning
- 2. Orthographic Projections (2 Sessions)**
Draw orthographic and sectional orthographic projections of machine components,
- 3. Machine Drawing (1 Session)**
Learning conventions and geometrical dimensioning through standard assembly and detail drawings of machine components
- 4. Isometric Drawing (2 Sessions)**
Isometric drawings of various solids and simple machine components
- 5. Computer aided drafting with AUTO CAD (3 Sessions)**
 - a. Introduction, advantages and applications of CAD, drawing, editing and modifying
 - b. Assigning annotations, dimensioning and line properties
 - c. Practice problems
- 6. Computer aided solid modeling with CATIA (10 Sessions)**

a. Introduction and use of sketcher workbench

Drawing and constraining sketches, performing sketch analysis

b. Creating base features (Part modeling)

Using operations like extrude (pad), revolve (shaft), sweep (rib) to create 3D base features

c. Boolean operations

Creating additional reference elements like point, lines and planes; performing Boolean operations like Add, Assemble, Remove, and Union trim to model machine components

d. Creating dress-up features

Fillets, chamfers, draft, shell, split, close volume solids

e. Generative Shape Design workbench (Surfacing)

Modeling and editing various surfaces (shapes)

f. Advanced Modeling

Modeling patterns, multi-section solids, symmetric features etc

g. Product design (Assembly modeling)

Assembling various part models.

h. Drafting Workbench

Obtaining and editing 2D drawings from 3D models

Text Books:

1. *N. D. Bhatt; Engineering Drawing; 50th edition, Charotar Publication.*
2. *Dhananjai A. Jolhe; Engineering Drawing with an introduction to AUTOCAD; 5th edition, Tata McGraw Hill education pvt.ltd., New Delhi.*
3. *C. M. Agawal, Basant Agrawal; Engineering Drawing; 2nd edition, Tata McGraw Hill education pvt.ltd., New Delhi.*
4. *Sham Tickoo; CATIA V5-6R2014 for Engineers and Designers; Dreamtech press.*

Reference Books:

1. *Warren J. Luzzader ; Fundamental of Engineering Drawing; Prentice Hall of India, New Delhi.*
2. *Venugopal K; Engineering Drawing and Graphics; New Age Internation Publishers.*
3. *K. L. Narayana and P. Kannaiah; Text book of Engineering Drawing; Scitech Publications, Chennai.*

Course Outcomes:

The student will be able to –

1. To learn standard practices of lines, lettering and dimensioning in Engineering Drawing.
2. Visualize and draw orthographic projections of 3D objects manually and with the help of AutoCAD software.
3. Visualize the object, draw isometric views manually and 3D objects using CATIA.
4. To plot the projection of lines and planes.
5. To draw the projections of solids and sections of solids.
6. To develop lateral surfaces of solids and interpret conventions used in drawing.

Course Name: Linear Algebra

Course Code: ES152

Course Type: THT

Credits: 3

**Teaching Scheme: Theory :2 Hours / Week
Tut :1 Hours / Week**

Unit I: Matrices and linear systems of equations (5 Hours)

Operations with matrices, Elementary transformations, Rank of a matrix, systems of linear equations

Unit II:Euclidean Vector Spaces (5 Hours)

Vectors in \mathbb{R}^n , vector spaces, subspaces, spanning sets and linear independence, basis and dimension

Unit III: General Vector Spaces (5 Hours)

Vector spaces of matrices, polynomials, $\mathcal{C}[a, b]$, $\mathcal{C}(-\infty, \infty)$

Unit IV: Inner Product Spaces (5 Hours)

Length and dot product in \mathbb{R}^n , Inner product spaces, Orthonormal Bases, Gram-Schmidt process

Unit V: Linear Transformations (4 Hours)

Introduction to Linear transformations, Range and Kernel of linear transformation, Matrices for linear transformations.

Unit VI. Eigen values and Eigen Vectors (6 Hours)

Eigen values and Eigen vectors, Diagonalization, symmetric matrices and orthogonal diagonalization, Quadratic forms and reduction of quadratic forms to canonical form, Application of eigen values and eigen vectors to rotation of axes, solution of system of first order linear differential equations.

List of Tutorials:

Tutorial Number	Topic	Mode of Conduct
1	Operations with matrices, Elementary transformations, Rank of a matrix	<ul style="list-style-type: none"> • Instructions • Basic problem solving • Home Assignment
2	Systems of linear equations	<ul style="list-style-type: none"> • Problem Solving • Use of mathematical Calculator / task • Home Assignment
3	Vectors in \mathbb{R}^n , vector spaces, subspaces	<ul style="list-style-type: none"> • Problem Solving • Home Assignment
4	Spanning sets and linear independence, basis and dimension	<ul style="list-style-type: none"> • Problem Solving • Group Project • Home Assignment
5	Vector spaces of matrices, polynomials	<ul style="list-style-type: none"> • Problem Solving • Home Assignment
6	Vector spaces of functions	<ul style="list-style-type: none"> • Problem Solving

	$C[a, b], C(-\infty, \infty)$	<ul style="list-style-type: none"> • Home Assignment
7	Mid semester Assessment	<ul style="list-style-type: none"> • Viva/MCQ test/Quiz
8	Length and dot product in R^m , Inner product spaces	<ul style="list-style-type: none"> • Problem Solving • Group Activity • Home Assignment
9	Orthonormal Bases, Gram-Schmidt process	<ul style="list-style-type: none"> • Problem Solving • Home Assignment
10	Introduction to Linear transformations, Range and Kernel of linear transformation	<ul style="list-style-type: none"> • Problem solving • Home Assignment
11	Matrices for linear transformations	<ul style="list-style-type: none"> • Problem solving • Group activity(Task) • Home Assignment
12	Eigen values and Eigen vectors, Diagonalization, symmetric matrices and orthogonal diagonalization	<ul style="list-style-type: none"> • Problem Solving • Group Project(Applications of eigen values and eigen vectors) • Use of calculator • Home Assignment
13	Quadratic forms and reduction of quadratic forms to canonical form, Application of eigen values and eigen vectors to rotation of axes, solution of system of first order linear differential equations.	<ul style="list-style-type: none"> • Problem Solving • Home Assignment
14	End semester assessment	<ul style="list-style-type: none"> • Viva/MCQ test/Quiz

Text Books:

1. Ron Larson and David C. Falvo, 'Linear Algebra An Introduction', 1st Edition, Cengage Learning (Indian Edition).

Reference Books:

1. David C. Lay ; Linear Algebra and its Applications; 12th edition; Pearson Education Inc.,
2. H. Anton, Elementary linear algebra with applications (8th Edition), John Wiley Publications
3. S. Kumaresan, 'Linear algebra - A Geometric approach', 1st Edition, Prentice Hall of India(Indian Edition)
4. Gilbert Strang; Linear Algebra and its Applications; 10th Indian reprint 2011;Cengage Learning (Indian Edition)

Course Outcomes:

The student will be able to –

1. Acquire the knowledge of systems of linear equations , Euclidean and general vector spaces, inner product spaces.
2. Analyze finite and infinite dimensional vector spaces and subspaces, matrix transformations.
3. compute orthonormal basis by Gram-Schmidt Process, eigen values, eigen vectors , obtain spectral decomposition represent quadratic forms and linear transformations algebraically and geometrically
4. Apply the knowledge of linear dependence, independence, inner product, eigen values and Cayley-Hamilton Theorem to find A^k .
5. Eigen vectors to find basis and dimension rank to determine solution of linear system of equations.

Course Name: Fundamentals of Programming

Course Code: CS151

Course Type: THL

Credits: 5

**Teaching Scheme: Theory :2 Hours / Week
Lab :4 Hours / Week**

Unit I: Introduction to programming (4 Hours)

Problem solving using computers; algorithms and flowcharts; using simplecpp graphics commands; notion of syntax and semantics; Repeating a block of commands; Nested repeat; numerical functions; comments; Data types; identifiers; initialization; const; Input and Output; Arithmetic operators; programming idioms; Compound assignment; blocks; scope and shadowing.

Unit II: Flow of Control (5 Hours)

Conditional Constructs: Relational and Logical Operators, various forms of if..else statements, ternary operator, switch..case statement;
Loops: Types of Loops, while, do..while, for, break and continue, goto statement.

Unit III: Array and Pointers (6 Hours)

Arrays: Definition, syntax, element operations, memory representation, initialization. Two dimensional array, row and column major;
Applications of arrays: sorting, searching and matrix operations;
Pointers: Definition, syntax, address of operator, pointer variables, relevance of data type in pointer variables, dereferencing operator, Pointer to pointer, address arithmetic;

Unit IV: Functions and Strings (5 hours)

Functions: Introduction; definition; anatomy of function; execution of function; Scope of various types of variable; scope; local and global variables; nested function call; returning values from function; Menu driven programs;
Strings: Introduction, Array of characters, output, input, character string constant, Accepting multiword string

Unit V: Structures and Introduction to Object Oriented Programming (5 Hours)

Structure: Need, User-defined Data Types, Derived Data Types ,Definition, syntax, declaration and initialization, structure variables, accessing and assigning values to structure variables, “dot” operator;
Introduction to OOPs : Benefits of OOP, applications, applications of C++, structure of C++ program, dynamic initialization of variables, scope resolution operator, operator overloading, precedence, Operators in C++, Reference Variables, Memory management operators, Manipulators

Unit VI: Functions, Classes and Objects (5 Hours)

Functions in C++, function prototyping, call and return by reference, inline functions, overloading, friend and virtual functions, Classes and objects, defining member functions, declaration of objects to class, access to member variables from objects etc , different forms of member functions

List of Practical:

Sr. No.	Topic
1	Graphics: Drawing basic diagrams using SimpleC++
2	Making computer calculate stuff : calculating average, finding roots of quadratic equation, complex numbers etc.
3	Switch statement: controlling the turtle
4	Loops, Conditionals and Arithmetic operations: Converting base of a number, Generating arithmetic and geometric progressions, Buttons on Canvas, Reversing n digit number etc.
5	Example: marks display program, find min/max Generate roll numbers
6	Linear and Binary Search
7	Bubble sort
8	Insertion and Selection Sort
9	Matrix arithmetic
10	Assignment on functions – menu driven programs, etc.
11	Create Structures for: student result, employee payroll, library book issuing
12	Write a program in C++ to demonstrate the use of reference variables/ scope resolution operator
13	Write a program in C++ to demonstrate the use of objects and function arguments
14	Write a program in C++ to demonstrate the use of classes and membership functions
15	Write a program in C++ to demonstrate function overloading

Text Books:

1. "An Introduction to Programming through C++ ", Abhiram Ranade, Mc Graw Hill Education. ISBN 978-9-33-290151-3
2. "Let us C", Y. Kanetkar, Second Edition, BPB Publication. ISBN: 8176566217.

Reference Books:

1. "Programming language – ANSI C", Brian W Kernighan and Dennis Ritchie, Second edition ISBN 0-13-110370-9
2. "Object Oriented Programming With C++", E Balagurusamy , Sixth edition ISBN: 9781259029936

Course Outcomes:

Upon completion of the course, graduates will be able to –

1. Apply programming fundamentals to construct concise solutions.
2. Demonstrate available algorithmic principles to generate efficient solutions.
3. Justify modular programming approach by making use of elementary as well as superior data structures.
4. Construct derived data type for real world entities.
5. Mapping real world objects using Object Oriented Programming concepts
6. Select appropriate programming paradigm to solve complex computing problem.

Course Name: Electrical Technology

Course Code: ES155

Course Type: THL

Credits: 4

**Teaching Scheme: Theory : 3 Hours / Week
Lab : 2 Hours / Week**

Unit I: D.C. Circuits

(7 Hours)

Ohm's law ,source transformation, Kirchhoff's law, Star delta, Network reduction , Superposition theorem, Thevenin's theorem, Norton's theorem, Maximum power transfer theorem. numerical .

Unit II: A.C. Circuits: Single phase

(7 Hours)

1 phase A.C. circuit RL,RC,RLC series, and parallel, phasor diagram, Average value . R.M.S value of a.c. quantity, peak factor , form factor. Concept of active , reactive ,VAR and power factor.numericals

Unit III: A.C. Circuits:Poly phase circuit.

(7 Hours)

3 Phase a.c. supply, phase sequence, concept of line , phase, neutral etc. Phasor diagram, active, reactive, apparent, power calculation,3 phase balanced star/delta connection. Numericals.

Unit IV: Transformer

(7 Hours)

Single phase, working principle,e.m.f. equation, ideal and practical transformer ,equivalent circuit, lossess ,regulation,efficiency calculation. Special transformers CT/PT , ferrite core transformers.no numericals.

Unit V: D.C. Machines

(7 Hours)

Construction, working principle, back e.m.f, torque equations, motor types, motor characteristics, speed control methods, problems. Different starters of d.c. motors.applications of d.c. motors

Unit VI: Three phase induction motor

(7 Hours)

Three phase induction motor, construction.RMF, working principles, slip ring and squirrel cage type,slip, slip torque characteristic, starters Different starters of induction motors. Applications of a.c. motors. numericals

List of Practical:

Sr. No.	Topic
1	Introduction to electrical component.
2	Load test on 1 phase transformers.
3	Load test on d.c. shunt motor.
4	Speed control of d.c. shunt motor.
5	Study of star and delta circuit.
6	Load test on three phase induction motor.

7	Lab Assignment : Electrical bill study
8	Substation visit.
9	Study of D.C. motor starter.
10	Study of A.C. motor starter

Text Books:

1. *Edward Hughes; Electrical Technology.*
2. *B.L.Theraja Vol-2; Electrical Technology.*
3. *H.Cotton; Electrical Technology.*

Reference Books:

1. *Electric Machinery, TMH(Sixth Edition)-Fitzgerald.*
2. *Electrical Machines, Drive and power system, Pearson education-Theodore Wildi.*
3. *Electric Machines, TMH-Nagrath Kothari.*
4. *Electrical Machines and transformers- Irving Kosow.*

Course Outcomes:

The student will be able to-

1. Understand different theorems and able to solve numericals on it.
2. Understand concept of single phase a.c. circuit.
3. Understand concept of three phase a.c. circuit.
4. Find losses and efficiency of single phase transformer.
5. Understand construction and working of DC machines and solve numerical problems.
6. Understand construction and working of induction motor and the T-S characteristic.

Course Name: Engineering Physics

Course Code: ES156

Course Type: THL

Credits: 4

Teaching Scheme: Theory :3 Hours / Week

Lab :2 Hours / Week

Unit I: Mechanical Waves

(7 Hours)

Oscillations and Waves: Simple Harmonic Motion, Simple Pendulum and Torsional Pendulum, Free, Damped, Forced and Coupled oscillations, Waves, Types of Waves, Wave equation, Boundary behavior and effects,

Sound and Acoustics: Characteristics of sound (Speed, Pitch, Timbre, Loudness), Weber Fechner Law, Sound Intensity (Decibel) and Pressure Level, Echo, Beats, Reverberation, Sabine's Formula (Qualitative), Remedies over reverberation, Sound absorption and absorbent materials, Building acoustics,

Ultrasonics: Ultrasonic wave production (Piezo electric and Magnetostriction method), Properties of ultrasonic waves, Detection of ultrasonic waves, Applications: Ultrasonic cleaning, Elastic constant measurement, SONAR, Ultrasonic welding, Non destructive testing, Sonography etc.

Unit II: Optics

(9 Hours)

Interference: Coherence, Thin film interference, Fringe width (wedge shaped film), Colours in thin films, Newton's rings and its applications, Michelson's interferometer and its applications, General applications: Optically flat surface, Antireflection coatings, Interference filters etc.

Diffraction: Fresnel and Fraunhofer diffraction, Single slit Fraunhofer diffraction, Plane diffraction grating (Qualitative), Dispersive power of grating, Resolving power, Rayleigh's criterion of resolution, Resolving power of grating and telescope, X - ray diffraction, Bragg's law, Bragg's X-ray spectrometer,

Polarization: Brewster's law, Malus law, Double refraction (Huygen's theory), Nicols prism, Retarders, Quarter wave plate (QWP), Half wave plate (HWP), Circularly and elliptically polarized light, Dichroism, Detection of polarized light, Applications: Polaroids, LCD, Photo-elasticity,

Unit III: Quantum Mechanics

(6 Hours)

Matter Waves: Limitations of classical mechanics (Rutherford's atomic model, Black body radiation, Photoelectric effect, Bohr atom model) and need of quantum mechanics, Wave particle duality, de-Broglie's hypothesis, Davisson - Germer Experiment, Phase and Group velocity, Heisenberg's uncertainty principle, Single slit electron diffraction, γ - ray microscope, applications of uncertainty principle,

Wave Equations: Wave function (ψ), Max Born's interpretation, Physical significance of ψ and ψ^2 , Schrödinger's wave equations and its applications: 1 D - Infinite potential well, Finite potential well (Qualitative), Tunneling effect, Scanning Tunneling Microscope (STM),

Unit IV: Semiconductor Physics

(7 Hours)

Semiconductors: Quantum numbers, Kronig-Penny Model (Qualitative), Band Theory of Solids, Energy Bands in C (Graphite, Diamond), Si, Ge, Sn, Ohm's Law (Microscopic), Temperature Dependence of Conductivity, Hall Effect, Fermi Level, Fermi-Dirac Probability Distribution Function, Fermi Level in Intrinsic (derivation) and Extrinsic Semiconductors

(Effect of Temperature and Doping Level on Fermi Energy), Working of p-n Junction Diode from Energy Band Diagrams, Photovoltaic Effect, Solar Cell Working and Characteristics,
Introductory Nanotechnology: Nanomaterials, Nanoparticles Properties (Quantum Size Effects: optical, electrical, magnetic, structural, mechanical), Zero, One, Two Dimensional Nanostructures, Nanomaterial Synthesis Techniques (Physical, Chemical etc.), Applications: Energy, Space, Electronics, Defense, Textile, Cosmetics, Medical, Environment, Automobiles,

Unit V: LASERS and Nuclear Physics **(7 Hours)**

LASERS: Stimulated Absorption, Spontaneous and Stimulated Emission, Population Inversion, Basic Requirements for Lasing Action, Laser Properties, Ruby Laser, He-Ne Laser, Semiconductor Diode Laser, Carbon Dioxide Laser (Principle, Construction and Working), Applications of Lasers (Industry : Drilling, Welding and Micromachining, Medical: Laser Eye, Skin, Cosmetic Surgery, Communication: Fiber Optics, Military Applications: Laser range detection, Laser Guided Missiles),

Nuclear Physics: Nuclear constituents, Atomic Mass Unit, Mass Defect, Binding Energy, Binding Energy Curve, Nuclear Fission, Q-value of Nuclear Reaction, Chain reaction, Nuclear Fusion, Distinction between Nuclear Fission and Fusion, Controlled Fusion, Ignition Temperature, Lawson’s Criteria, Fusion Reactors, Confinement Schemes: Gravitational, Magnetic, Inertial, Laser Fusion Reactor.

Unit VI: Magnetic Materials and Superconductivity **(6 Hours)**

Magnetic Materials: Magnetic field (B), Permeability, Magnetic Field Strength (H), Magnetic Susceptibility, Magnetization, The Bohr Magnetron, Curie’s Law, Hysteresis, Magnetic materials: Dia, para, ferromagnetic, ferrimagnetic, Applications: Transformer cores, Electromagnetic shielding,

Superconductivity: Properties (Zero Resistance, Meissner Effect, Critical Fields, Persistent Currents, Critical Current Density, London Penetration Depth, Isotope Effect), Type I and II Superconductors, BCS Theory, High T_c Superconductors and its preparation, DC and AC Josephson Effect, Applications: Superconducting Quantum Interference Devices (SQUID), Transmission Lines, Superconducting Magnets, Maglev Trains,

List of Practical: (Students will perform any Five experiments as per following code of conduct in physics laboratory)

Sr. No.	Name of the Experiment	Mode of Conduct
1.	Simple pendulum and coupled pendulum	Any one of two / three to be performed by students and other for demonstration of working principle.
	Determination of speed of ultrasonic waves in water and to determine the compressibility of liquid using Ultrasonic Interferometer	
	Measurement of sound pressure level and absorption coefficient of sound of different materials	
2.	Determination of wavelength of light / radius of curvature of plano-convex lens using Newton’s ring experiment	
	Determination of Wavelength of Light using Michelson’s Interferometer	
	Use of diffraction grating for the determination of wavelength of spectral line and determination of resolution of spectral lines using diffraction grating and spectrometer	

3.	Polarization by Refraction: Malus Law Determination of Brewster's angle for glass surface and refractive index of glass. Demonstration of Lissajous figures using a CRO (Principle of interference) concepts of polarization – Plane, Circular and Elliptical Polarization	Projects will be allotted in groups at the beginning of semester.
4.	Determination of band gap of a semiconductor. Hall Effect, determination of Hall coefficient.	
5.	Characteristics of solar cell, calculation of fill factor. Determination of wavelength and thickness of wire using LASER and determination of beam divergence of LASER.	
6.	Course Project Work	
7.	Course Project Work	
8.	Course Project Work	
9.	Course Project Work	
10.	Course Project Work	
11.	Course Project Work	
12.	Course Project Work	

In addition to above experiments students must perform the following all experiments in virtual laboratory environment which is developed by Amrita Vishwa Vidyapeetham under the NME ICT initiative of MHRD, Government of India.

Sr. No.	Name of the Experiment	Link
1	Torsional oscillations in different liquids	http://vlab.amrita.edu/?sub=1&brch=74
2	Kundt's Tube Apparatus	http://vlab.amrita.edu/?sub=1&brch=201&sim=853&cnt=7
3	Ultrasonic Interferometer	http://vlab.amrita.edu/?sub=1&brch=201&sim=803&cnt=1
4	Newton's Rings-Wavelength of light	http://vlab.amrita.edu/?sub=1&brch=189&sim=335&cnt=1
5	Newton's Rings-Refractive index of liquid	http://vlab.amrita.edu/?sub=1&brch=189&sim=1520&cnt=1
6	Michelson's Interferometer-Refractive index of glass plate	http://vlab.amrita.edu/?sub=1&brch=189&sim=1519&cnt=1
7	Michelson's Interferometer-Wavelength of laser beam	http://vlab.amrita.edu/?sub=1&brch=189&sim=1106&cnt=1
8	Diffraction Grating	http://vlab.amrita.edu/?sub=1&brch=281&sim=334&cnt=1
9	Brewsters Angle determination	http://vlab.amrita.edu/?sub=1&brch=189&sim=333&cnt=1
10	Emission spectra	http://vlab.amrita.edu/?sub=1&brch=195&sim=359&cnt=1
11	Photoelectric effect	http://vlab.amrita.edu/?sub=1&brch=195&sim=840&cnt=1
12	Determination of Planck's Constant	http://vlab.amrita.edu/?sub=1&brch=195&sim=547

		&cnt=1
13	Hall effect experiment:- Determination of charge carrier density	http://vlab.amrita.edu/?sub=1&brch=282&sim=879 &cnt=1
14	Solar Panel Experiment (Remote Trigger)	http://vlab.amrita.edu/?sub=1&brch=195&sim=360 &cnt=1
15	Laser beam divergence and spot size	http://vlab.amrita.edu/?sub=1&brch=189&sim=342 &cnt=1
16	B-H Curve	http://vlab.amrita.edu/?sub=1&brch=282&sim=1507 &cnt=1
17	Magnetic Material Characterization via Hysteresis (Remote Trigger)	http://vlab.amrita.edu/?sub=1&brch=195&sim=800 &cnt=1

Text Books:

1. *M.N. Avadhanalu, P.G. Kshirsagar; A Textbook of Engineering Physics, Revised Edition 2014, S. Chand Technical Publishers, New Delhi,*
2. *A. Beiser, Concepts of Modern Physics, (6th) New 2005, Tata McGraw Hill Pub. Co., New Delhi,*
3. *H. K. Malik, A. K. Singh, Engineering Physics, 2010, Tata McGraw Hill, New Delhi,*

Reference Books:

1. *R. J. Serway and J. W. Jewett, Physics for Scientists and Engineers with Modern Physics, 5th / 6th / 7th Edition 2010, Thomson / Cengage Learning, New Delhi,*
2. *Young and Freedman, University Physics, 10th / 11th / 12th / 13th Edition, Pearson Education*
3. *Resnick and Halliday, Fundamentals of Physics, 8th / 9th / 10th Edition, John Wiley and Sons.*

Course Outcomes:

The student will be able to –

1. derive, distinguish, analyze, elucidate and solve problems from the topics of Oscillations, Sound waves and Ultrasonics and experiment (e.g. pendulum, oscillations, ultrasonics etc.)
2. distinguish, analyze, determine the physical terms from thin film interference, diffraction, polarization and to measure experimentally (e.g. radius of curvature, spectral resolution, Brewster's angle etc.)
3. recognize, justify, utilize the fundamental principles of quantum mechanics to solve problems and to interpret the applications in the quantum regime.
4. derive, draw, evaluate, compute the physical terms in semiconductor physics (Fermi Energy, Energy band diagrams etc.), and to experiment the basic semiconductor devices (e.g. solar cell, pn junction diode etc.) and differentiate, analyze the properties at nano scale, nano-materials and interpret their applications.
5. differentiate, correlate, interpret the working mechanism and applications of different lasers (He-Ne laser, Ruby laser etc.) experiment on lasers and distinguish, analyze, justify the concepts from Nuclear Physics (Fission, Fusion etc.) solve the problems on binding energy, fusion etc.
6. analyze, interpret, distinguish, calculate and solve the basic problems for magnetic materials (magnetization, hysteresis) and superconductivity (e.g. critical temperature, penetration depth etc.) and elucidate their applications.

Course Name: Indian Philosophy and Ethics

Course Code: HS151

Course Type: TH

Credits: 2

Teaching Scheme: Theory: 2 Hours / Week

Unit I: Introduction & The Philosophy of Logic and Reasoning (Nyaya) (6 Hours)

Introduction to “The Six Systems of Indian Philosophy of Ancient India”. The Philosophy of Logic and Reasoning (Nyaya). Sources of Valid Knowledge with their merits and de-merits. Importance of Testimony and the Logic presented to argue for the sake of a creator v/s the argument presented against one. The various objects of knowledge (Prameya)

Unit II: Dualism (Sankhya) and Analysis of Aspects of Reality (Vaisheshika) (6 Hours)

The Dualistic Model, French Philosopher Rene Descartes and his ideas on Dualism, Indian system of Dualism (Sankhya) : Analogies and Validations presented for the idea of self separate from the body, Reincarnation cases, Consciousness: The mysterious missing link. The three modes of material nature and their effects on consciousness. Analysis of aspects of Reality (Vaisheshika) : Effect of Illusion on the mind and the goal of the six systems of Indian philosophy.

Unit III: Self Discipline for Self Realization (Yoga sutras) (4 Hours)

Detailed analysis of the nature of mind and the interaction of the mind and senses. The 8-fold path of Ashtanga Yoga as per Patanjali Yoga sutras and the purpose of the Yoga system.

Unit IV: The Higher Deliberation (Uttara Mimamsa) (4 Hours)

The Vedantic Model : The various aspects of Absolute Truth, The interaction between material nature (Prkrti) , Self (Jiva) and Absolute Self (Purusha). Comparison of the Vedantic Model with other theistic philosophies. The Bhakti Yoga model as compared to Yoga Sutras of Patanjali.

Unit V : Elevation through performance of duty (Karma Mimamsa) (4 Hours)

The Universal Law and Order (The web of Karma), Polytheistic model v/s Monotheistic model, Karma Yoga model. Universal utilities and the purpose of ritualism.

Unit VI: Ethics from Indian Epics (4 Hours)

Ethics related to Leadership, Cooperation, Team Spirit, Competitiveness, Wealth and Friendship from Chanakya Niti and Mahabharat.

Text Books:

1. *Rajiv Malhotra ,Being Different’ : An Indian Challenge to Western Universalism, Happer Collins Publishers India. ISBN No : 978-93-5116-050-2*
2. *Suhotra Dasa Tapovanachari, The Six systems of Vedic Philosophy, (Online PDF book)*

Reference Books:

1. *Devamrita Swami, Searching for the Vedic India, Bhaktivedanta Book Trust. ISBN 0-89213-350-3*
2. *Patita Pavan , Sri Chanakya Niti: Ancient Sense for Modern Success, ISBN 978-93-82109-25-9. Abhay Ashram Publishing.*
3. *Govinda das, Voice your choice: Ethics from Epics, White Woods Publishing House. ISBN : 978-93-81-283042*

4. *Hornyanszky, Istvan Tasi. Nature's IQ Balazs Torchlight Publishing ISB: 978-0-9817273-0-1.*

Course Outcomes:

The student will be able to –

1. Apply the most appropriate tool of acquiring knowledge for a suitable object of knowledge.
2. Discern the reasons for the dual model of self & body and effects of the three modes on consciousness.
3. Evaluate the purpose of the 8 steps of the Yoga sutras and their consequence on the human mind.
4. Contrast the aspects of Absolute truth as laid out by the Vedanta model with the world's theistic philosophies.
5. Argue for the sake of Universal Law of Karma and the differences between monotheistic and polytheistic models.
6. Practice ethics in one's personal, professional and family life.

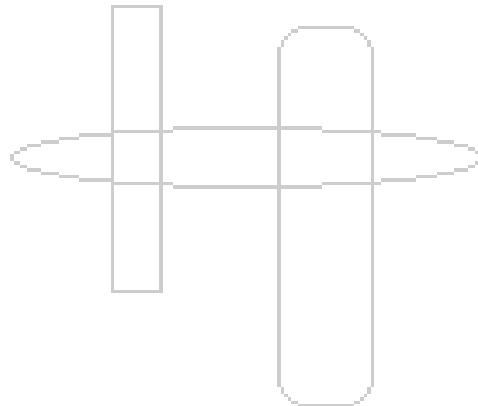

Course Name: German

Course Code: HS102

Course Type: LTH

Credits:2

**Teaching Scheme: Theory : 2 Hours / Week
Lab : 2 Hours / Week**

Unit I: Introduction to German (4 Hours)

Alphabets and sounds. International words in German. Introducing oneself and others. Times of the day. Greetings according to time of the day. Listening to conversations in day life situations

Grammar: Personal pronouns. Conjugations of weak verbs.

Unit II: Food and drinks (5 Hours)

Starting conversations. Meeting in Cafes. Vocabulary for food and drinks. Ordering food and paying the bill. Numbers. 1-1000. Tell and understand telephone numbers. Dates. Cities and countries. Nationalities and languages.

Grammar: Present and past tense of to be and have. Strong verbs. Forming and answering Wh questions and closed questions. Definite, indefinite articles. Singular and plural.

Unit III: Living in Germany (5 Hours)

Types of Houses, Types of Rooms, Description of rooms. Furniture in the house. Countries, nationalities and languages. Directions and telling location. Family and relationships. Hobbies and pass time activities.

Grammar: Adjectives and Opposites. Nominative and Accusative cases. Negation

Unit IV: Time (5 Hours)

Writing E-Mails, Times of the day, weekdays and months. Learning clock hours, Taking formal appointments and casual meetings. Describing daily routine. Giving excuses for delays and absence. Professions and the describing responsibilities involved in that professions.

Grammar: Possessive pronouns. Separable verbs

Unit V: Professions and responsibilities (5 Hours)

Asking for place of work and answering Mode of transport for the same. Orientation of a workplace. Different professions and professional life. Responsibilities at the workplace.

Grammar: Wechsel prepositions and variable cases, Ordinal numbers

Unit VI: An excursion through Berlin (4 Hours)

Tourism in Berlin, culture, places worth visiting, planning trips with the help of city map and bus / tram schedules. Narrating a trip. Asking for road directions and giving them to others.

Grammar: Modal verbs, writing a post card.

List of Practicals:

Sr. No.	Description	Mode of Conduct
1.	Singing alphabet rap song to learn German alphabets. Listen and practice different sounds that alphabets make in different combinations. Spelling each other's names etc	Use of Audio, video sessions, group activities and games.

2.	Starting the dialogues with self introduction. Basic conversations. Audio sessions from book.	
3.	Practicing numbers. 0 – 1000. Practicing numbers in pairs asking each other's age, phone no. birth dates etc. Audio sessions from book.	
4.	Classroom scene enactment; "first day of the course". Audio sessions from book	
5.	Written exercises from book and work book based on first 2 topics	
6.	Games based on vocabulary related to classroom like placing right name chits on right item in the class. Audio sessions from book.	
7.	Conversations in travel about countries and languages. Audio sessions from the book. Solving exercise in work books.	
8.	Writing an essay on "my family". Reading that in class.	
9.	Picture description: theme "Types of houses, rooms and things in houses". Write description of their own house.	
10.	Writing emails and SMSs. Using time schedules given at different places, planning activities or taking appointments in formal / informal setting and cancelling it.	
11.	Practicing and enacting the telephonic conversation with friends for planning some social outing.	
12.	Practicing dialogues in pairs where you talk about the profession you are in and describe the responsibilities you have at work place. Writing an essay on an excursion.	

Text Books:

1. *Studio d A1 Deutsch als Fremdsprache – Kurs- und Uebungsbuch – by Funk, Kuhn and Demme published by GOYAL SaaB and Cornelsen*

Course Outcomes:

The student will be able to –

1. Pronounce the words correctly according German language rules and formulate small and simple sentences in German using basic grammar structures.
2. Describe various types of houses and furniture items in various rooms of a house.
3. Make a conversation in German in daily life situations using vocabulary related to classrooms, family, restaurants, jobs, days, months etc
4. Write emails, SMS or small essays in German.
5. Read and understand small texts, advertisements, instructions in German.
6. Read and tell time and use it for making an appointment and cancelling it.

Course Name: French

Course Code: HS105

Course Type: LTH

Credits:2

**Teaching Scheme: Theory : 2 Hours / Week
Lab : 2 Hours / Week**

Unit I: Introduction

(4 Hours)

- Alphabets, Numbers (0-100), Months, days of the week
- Difference between Tu/Vous.
- Self Introduction, Date of birth, Telephone numbers.
- Basic salutations.
- Indefinite Articles (c'est ce sont)

Unit II : Ecole de francais, Paris: Au secrétariat

(4 Hours)

- Definite Articles, Pronom tonique .
- Introduction of third person, Nationalities, professions
- Irregular verbs –Etre / Avoir.
- Vocabulary related to family and colours.

Unit III: Autour de l'école

(4 Hours)

- Regular « er » ending verbs.
- Prepositions, Directions
- Verbs « aller, venir, faire »
- Plural on nouns and adjectives.
- Les Articles Contractes.

Unit IV: La vie quotidienne

(6 Hours)

- Quelle heure est- il?
- Ma Journée
- Réflexive/Pronominal verbs
- Interrogation (yes /no and wh type)
- Regular “ir” ending verbs
- Concept of si, oui and non.

Unit V: Ma chambre

(6 Hours)

- Le Futur Proche.
- Vocabulary for room and house.
- Les saisons
- Les adjectifs possessifs.
- Verbs (Sortir, Partir, prendre)

Unit VI: Une Randonnée

(4 Hours)

- La négation.
- Parts of Body and Face
- Concept of Jouer a/jouer de.
- Les adjectifs qualificatifs

List of Practical:

Sr. No.	Description	Mode of Conduct
1.	A small dialogue using the basic vocabulary. A game on numbers. Spelling one's name or Name game. oral revision	Games, Dialogues, General conversation, cd listening and chalk and board.
2.	Ask the students to solve workbook exercises on indefinite articles. Telephonic conversation using the vocabulary done in class.	
3	Listening of unit 0, Game on professions and nationality. Self Introduction	
4	Game on Introduction of third person, Writing small essay on your family, Dictation.	
5.	Picture description. Making sentences using avoir /etre.	
6.	Listening and dialogue using directions and prepositions.	Games, Dialogues, General conversation, cd listening and chalk and board.
7.	Telling and writing ones routine and make 10 sentences using reflexive verbs.	
8.	Describe your room and house using the given vocabulary	
9.	Write a small essay on seasons of India or France. Write a small essay on My Favourite Season.	
10.	Workbook exercises and translation exercises, listening exercises.	
11.	Plan for a picnic or some event and perform a dialogue.	
12.	Picture description using given vocabulary and imagining the situation. Practice for orals.	

Course Outcomes:

The student will be able to –

1. Greet formally as well as informally and introduce himself or herself in French and ask basic questions.
2. Read and write numbers, dates, telephone numbers, days of the week and ask or tell the directions to reach the destination and form grammatically correct sentences.
3. Have dialogues in classroom, office, restaurant etc and with family using related vocabulary.
4. Describe the room, house and tell your routine using vocabulary related to colours and adjectives.
5. Write emails, letters and small essays in French.
6. Read , write and understand small texts, passages and instructions in French.

Course Name: Soft Skills**Course Code: HS153****Course Type: LTH****Credits: 2****Teaching Scheme: Theory :1 Hours / Week
Lab :2 Hours / Week****Unit I: Introduction to soft skills and self analysis (2 Hours)**

- Goal setting and career planning: dreams and goals; Short term, medium and long term goals. Setting SMART goals
- Introduction and meaning of soft skills; difference between soft skills and hard skills, importance of soft skills in corporate world, Concepts of IQ, EQ and SQ
- Influence of cultural differences on soft skills
- Self analysis. Knowing yourself; birth dates, height, weight, etc.
- SWOT (activity based explanation)

Unit II: Communication skills and listening skills (2 Hours)

- Communication skills: Meaning, need, significance and types (written/oral, formal/informal, internal/external etc), Barriers in communication.
- How to start a communication? Communication process (Articulation of thought) Concept of KISS, Importance of non-verbal communication.
- Public speaking meaning ,do's and don'ts

Unit III: Listening skills (2 Hours)

- Meaning, difference between listening and hearing, process of listening
- Types: active, passive, evaluative, discriminative listening, intuitive, selective, pretence
- Barriers in listening. Physical barriers, People related barriers (Physiological barriers, Psychological barriers), Tips for being a good listener

Unit IV: Team building and leadership (3 Hours)

- Team building and leadership, Introduction to leadership skills.
- Concept of team: difference between team and group, process of team building, significance and methods to develop team spirit.
- Characteristics of a leader. Walk the talk. Difference between a leader and manager.

Unit V: Time management and problem solving (3 Hours)

- Creativity and problem solving, Introduction to problem solving concepts and techniques.
- Time management (Concept and importance), Abstract thinking and critical thinking.(Out of the box thinking)

Unit VI: Professional etiquettes (1 Hours)

- Etiquettes and manners: meaning and significance, Attitude, organizational ethics
- Telephonic etiquettes, table manners, professional etiquettes, hygiene and clothing manners.

List of Practicals:

Sr. No.	Description	Mode of Conduct
1.	Breaking the ice. Interaction with students with their introduction session and discussing their future plans.	Use of Audio, video sessions,

	Demonstration and open discussions about cultural differences in soft skills	demonstrations, group activities and games, scene enactments.
2.	Start with a small session of meditation where they are asked to focus on self, likes, dislikes, etc. Then ask to do SWOT test. Then again discuss their dreams and goals to align with their SWOT analysis.	
3.	Asking the students to introduce themselves in the class and then explaining them importance of short and crisp introduction along with some examples.	
4.	Role play to elaborate on the importance of communication skills and explain the students the dos and don'ts for good and effective communication.	
5.	Students will be given a topic to prepare at home which they will be discussing or briefing in the class.	
6.	Some exercises based on reading and listening will be discussed and solved in the class.	
7.	Students will be given some topics related to latest issues for which they will be given some preparation time; they will work in groups and discuss the same in the group (group discussion).	
8.	Video session. In this session students will be shown a film on team building and then they will discuss based on the topic.	
9.	Group activity like making maximum paper planes, where students have to exhibit their leadership qualities, team building skills and effective team playing as well.	
10.	The teacher will identify some business problems which the students have to solve looking at the present scenario and the concept of problem solving and creativity.	
11.	Video of Mr D.S.Kulkarni to be shown in the class and discussed ask students to get some more examples of people who have come far away in their lives.	
12.	A game or an activity related to manners, etiquettes and hygiene.	

Text Books:

1. *Soft Skills* by Dr. K Alex. S.Chand and company ltd.

Course Outcomes:

The student will be able to –

1. Set his / her goals for future and start preparing accordingly.
2. Apply proper communication skills and hence enable him to be an effective communicator.
3. Become a good listener and perform his / her tasks as per expectations.
4. Lead a team successfully and work as a good team player as well.
5. Apply creativity and time management skills to solve problems related to work.
6. Demonstrate professional etiquettes in a workplace.

Course Name: Manufacturing Workshop

Course Code: ME153

Course Type: L

Credits: 1

Teaching Scheme: Lab:2 Hours / Week

Unit I: Carpentry

Introduction, Use of marking tools and hand tools such as marking gauge, try squares, steel rules, saws, jack plane, chisels etc. Use of power tools, Safety precautions. Demonstration and one job involving different operations such as sawing, planning and chiseling etc.

Unit II: Welding

Introduction, Principle of manual metal arc welding, equipment and its operation, welding electrodes, welding joints, welding symbols, safety precautions, demonstration and one job on mild steel

Unit III: Mini Project

Besides the above jobs students in groups will make an article / gadget / model / setup in involving the work of above work trades and / or other work trades.

Text Books:

1. *S. K. Harja Chudhary, Elements of Workshop Technology, Media Promoters and Publishers Pvt. Ltd.*
2. *K. T. Kulkarni Introduction to Industrial Safety,*

Reference Books:

1. *H. Geng, Manufacturing Engineering Hand Book, McGraw Hill Publishing Co.Ltd..*
2. *L. E. Doyle, Manufacturing Processes and Materials for Engineering, Prentice Hall Inc.,*

Course Outcome:

The student will be able to

1. Perform few carpentry and welding operations
2. Follow safety practices

Course Name: Fundamental Mathematics

Course Code: ES157

Course Type: AU

Credits: Audit

Teaching Scheme: Theory :2 Hours / Week

Unit I: Matrices and Determinants **(04 Hours)**

Algebra of matrices, Determinants and their properties. Inverse of a matrix. Cramer's rule, basics of vector algebra

Unit II: Trigonometry, Limits and continuity **(05 Hours)**

Measurement of angles, trigonometric ratios, trigonometric functions, Elementary functions and their graphs, Inverse functions, Limit. Continuity

Unit III: Differentiation and Integration **(05 Hours)**

Derivative and its geometrical significance, Maxima and Minima and Lagrange's Mean value theorem. Integration as the inverse process of differentiation, Integration by parts and by substitution, Definite integral and its physical significance

Unit IV: Complex numbers **(05 Hours)**

Complex numbers as ordered pairs. Argand's diagram. Triangle inequality. De Moivre's Theorem, Hyperbolic functions.

Unit V: Basics of set theory and Logic **(04 Hours)**

Sets and their representations, Subsets, Power set, Universal set, Venn diagrams, Algebra of Sets, Set Identities, Basics of Logic

Unit VI: Basics of Probability **(05 Hours)**

Factorial n ($n!$), Permutations and combinations, Random experiments: outcomes, sample spaces (set representation) Events, exhaustive events, mutually exclusive events, Axiomatic definition of Probability

Text Books:

1. B. S. Grewal, 'Higher Engineering Mathematics', 40th Edition, Khanna Publications.

Reference Books:

1. Thomas G. B. and Finney, 'Calculus and analytic Geometry', 11th Edition, Pearson Publications

2. Ron Larson and David C. Falvo, 'Linear Algebra An Introduction', 1st Edition, Cengage Learning (Indian Edition).

Course Outcomes:

The student will be able to –

1. Apply the knowledge of matrices, determinants, elementary functions, limits and continuity
2. Solve problems on limit, continuity, derivatives and integration and Argand's diagram
3. Demonstrate the knowledge of complex numbers, hyperbolic functions, trigonometry
4. Apply the knowledge of set theoretic notations and concepts in real life problems.
5. Identify and use of basic probability concepts and vectors

Course Name: English

Course Code: HS101

Course Type: AU

Credits: Audit

Teaching Scheme: Theory:2 Hours / Week

Unit I: Vocabulary

(4 Hours)

- Word Formation
- Correct Usage
- Idiomatic Expressions

Unit II: Basic Grammar

(6 Hours)

- Articles
- Parts of Speech
- Sentence Structure
- Verbs and Concord
- Question tags
- short responses

Unit III: Listening Skills

(4 Hours)

- Kinds of Sentences
- Verbs Modals
- Conjunctions

Unit IV: Speaking Skills

(6 Hours)

- Direct and Indirect speech
- Description
- Narration
- Conversation

Unit V: Reading Skills

(4 Hours)

- Active Passive Voice
- Prepositions
- Improved Spelling

Unit VI: Writing Skills

(6 Hours)

- Paragraph Writing
- Punctuation
- Note-making

List of Practicals:

Sr. No.	Description	Mode of Conduct
1.	Self- Introduction	

2.	Review a film clipping	Use of Audio, video sessions, demonstrations, group activities and games, scene enactments.
3.	Guess the word, Telephonic Conversations	
4.	Dumb Charades	
5.	Dialogues, Situational conversation, Relay conversation.	
6.	Analyse a newspaper article	
7.	Spot the error, clues.	
8.	Newspaper articles, Reports, Editorials.	
9.	Picture Composition	
10.	Paragraph Writing	
11.	Group Activity-follow instructions, enacting.	
12.	Crossword Puzzles, Scramble	
13.	Memory Games.	
14.	Chinese Whispers, Follow Instructions	

Text Books:

1. *Wren and Martin, “English Grammer and Composition” S. Chand Publications*

Reference Books:

1. *Bansal and Harrison- Spoken English in India*
2. *Essentials of Grammar and Composition*
3. *Lewis- The New Roget’s Thesaurus in Dictionary Form*
4. *Oxford English for Careers:Engineering 1 Student’s Book. Oxford University Press*

Course Outcomes:

The student will be able to –

1. Enhance their vocabulary skills
2. Construct and use grammatically correct sentences.
3. Develop good listening skills.
4. Speak confidently in English.
5. To be able to comprehend the printed content
6. Write appropriately to communicate effectively

Course Name: Environmental Science

Course Code: HS155

Course Type: AU

Credits: Audit

Teaching Scheme: Theory :2 Hours / Week

Unit I: Renewable and Non-renewable Resources (05 Hours)

Definition, scope, importance and multidisciplinary Nature of Environmental Studies. Definition and types of resources based on different heads, Natural resources and associated problems, role of an individual in conservation of natural resources, equitable use of resources in achieving sustainable development.

Unit II : Ecosystems (05 Hours)

Concept of an Ecosystem, Structure and Function of various components of an Ecosystem, Energy Flow in an Ecosystem, Ecological Succession, Ecological Pyramids for different types of Ecosystems, food chain, food web, interdependency of components of ecosystem over each other.

Unit III: Biodiversity and its conservation (05 Hours)

Introduction, Definition, genetic, species and ecosystem diversity, Biogeographical classification of India, Value of Biodiversity: consumptive use, productive use, social, ethical, aesthetic and option values, Biodiversity at global, National and local levels, India as a mega-diversity nation.

Unit IV: Environmental Pollution (05 Hours)

Definition of Pollution, various terms related to pollution, types of pollution, pollutants, types of pollutants, causes, effects and remedial measures of different types of pollution, role of an individual to prevent the pollution.

Unit V: Disaster and Hazardous Waste Management (05 Hours)

Disaster management: floods, earthquakes, cyclones and landslides. Integrated solid waste management, 3R principle, hazardous waste management, biomedical waste treatment technologies and disposal options, e-waste management, waste minimization for sustainability, waste management – Indian scenario.

Unit VI: Social Issues and Environment (05 Hours)

Urban problems related to energy, Water conservation, environmental ethics, wasteland reclamation, consumerism and waste products, EIA, Environment and human health, Human rights, value education, Public awareness, Role of modern technology.

Text Books:

1. *Erich Bharucha;Textbook of Environmental Studies for Undergraduate Courses,Second Edition,UGC Publications.*
2. *Mackenzie L. Davis and David A. Cornwell.2010. Introduction to Environmental Engineering, 4e. Tata McGraw-Hill Education Private Limited New Delhi.*

Reference Books:

1. *Gilbert M. Masters.2007. Introduction to Environmental Engineering and Science, 2e. Pearson Education. Dorling Kindersley (India) Pvt. Ltd. Delhi.*

2. *J. Glynn Henry and Gary W. Heinke.2004. Environmental Science and Engineering, 2e. Pearson Education (Singapore) Pte. Ltd.*

Course Outcomes:

The student will be able to,

1. Recognize renewable and non-renewable resources and associated problems and plan different activities to create awareness among the people and hence to conserve resources by minimizing degradation of environment.
2. Understand different types of ecosystems and their importance in balancing the nature.
3. Understand concept of biodiversity at national and global level and need to preserve it.
4. Understand different types of pollutions and hence to find the remedial measures to minimize ill effects.
5. Recognize various disaster and solid waste management techniques.
6. Understand and appreciate the ethical, cross-cultural, and historical context of environmental issues and the links between human and natural systems.

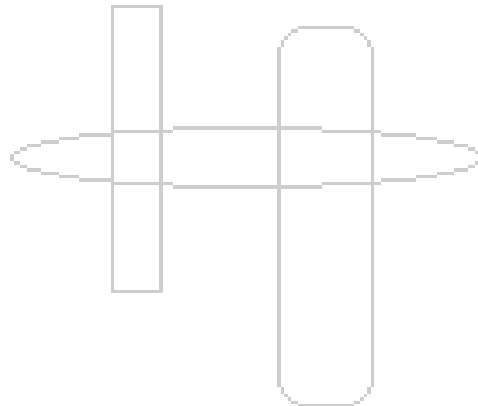

Course Name: Machining Workshop

Course Code: ME154

Course Type: L

Credits: 1

Teaching Scheme: Lab

:2 Hours / Week

Unit I: Fitting

Introduction, Use of marking tools such as vernier caliper, vernier height gauge, micrometer, center punch, try squares, steel rule, and hand tools such as files, hand saw, chisels, taps, bench vice, angle plate, surface plate etc. Safety Precautions, One job involving different operations such as sawing, tapping, filling and chiseling etc.

Unit II: Turning

Introduction to Lathe machine, Main parts and their functions. Lathe operations such as turning, facing, chamfering, drilling etc. Measuring instruments like vernier caliper, micrometer etc. safety precautions, demonstration and one job on mild steel

Unit III: Milling

Introduction of Milling machine, Main parts and their functions, safety precautions, demonstration of plain milling operation,

Unit IV: Sheet Metal and Press Work

Introduction, Use of marking and hand tools such as marker, scissors, measuring gauge, soldering iron etc. safety precautions, demonstration and hands on experience of few operations such as marking, cutting, bending etc. Introduction of fly press and cuttings dye punch along with its demonstration

Text Books:

1. *S. K. Harja Chudhary, Elements of Workshop Technology, Media Promoters and Publishers Pvt. Ltd.*
2. *K. T. Kulkarni Introduction to Industrial Safety,*

Reference Books:

1. *H. Geng, Manufacturing Engineering Hand Book, McGraw Hill Publishing Co.Ltd..*
2. *L. E. Doyle, Manufacturing Processes and Materials for Engineering, Prentice Hall Inc.,*

Course Outcome:

The student will be able to

1. Perform few fitting and turning operations
2. Follow safety practices

Course Name: General Seminar

Course Code: HS154

Course Type: L

Credits: 2

Teaching Scheme: Lab :2 Hours / Week

Unit I: Formal Written skills **(2 Hours)**

- Office Drafting- Circulars ,Notice ,Memos.
- Job application with resume /CV
- Covering Letters for resume/ CV
- Business correspondence- Enquiry, Order letter, Complaint letter, Adjustment letter.
- Report writing.

Unit II: Public speaking **(2 Hours)**

- Mastering the ABCs of public speaking.
- Speech preparation.
- Public speaking meaning ,do's and don'ts
- How to be an effective public speaker.

Unit III: Presentations. **(2 Hours)**

- Guidelines for a successful presentation.
- Effective Power point design using visual aids.
- Practicing delivery of presentation.

Unit IV:Project literature survey **(3 Hours)**

- Guidelines for a literature survey.
- Difference between Literature survey and field survey.
- Making a literature survey.

Unit V: Group Discussion **(3 Hours)**

- Introduction and meaning of group discussion.
- Essential elements of group discussion.
- Skills required /Initiation/ Techniques
- Movement and gestures to be avoided.
- Non verbal communication in group discussion.

Unit VI: Interview Techniques **(1 Hour)**

- How to present well in Interviews.
- Basic tips and how to search a job effectively.
- Telephonic interviews.
- Dress code/typical questions/Interview mistakes.

List of Practical:

Sr. No.	Description	Mode of Conduct
1.	Practice of application writing,reports,memos,circulars and assignments to be conducted.	

2.	Extempore to be taken in class and each student to be given a topic to speak on the same.	Use of Audio, video sessions, demonstrations, group activities and games, scene enactments.
3.	Topics to be allotted to students and with guidance of teacher making the presentation in class.	
4.	A mini project assigned in groups and elaborating the literature survey of the given topic.	
5.	Students will be given a topic to prepare at home which they will be discussing or briefing in the class.	
6.	Public speaking topics to be discussed and students will be encouraged to participate in class.	
7.	Students will be given some topics related to latest issues for which they will be given some preparation time; they will work in groups and discuss the same in the group (group discussion).	
8.	Group discussion on a topic of their choice in which the coordination and leadership qualities of the student will be evaluated.	
9.	Various topic related activities will be conducted in class.	
10.	Mock interviews will be conducted and each and every student shall be evaluated during class.	
11.	Different videos, motivational speeches, inspirational guidance and knowledge will be imparted to the students.	
12.	Games and topic related activities will be conducted and every students participation will be encouraged.	

Text Books:

1. *Dr .K .Alex, Soft skills, S.Chand & Company Ltd.*

Course Outcomes:

The student will able to

1. Gain confidence and will be able to face interviews.
2. Make professional presentations and reports.
3. Learn to be a Team member and cooperate .
4. Lead a team successfully and work as a good team player as well.
5. Stand out in a crowd with the skills provided.
6. Thorough Professional with the above training provided.

Annexure I**List of General Proficiency Courses offered to F.Y. B.Tech. AY 2016-17****For Detail Syllabus Kindly refer GP course booklet**

Course Code	Name of Course
GP101	Aerobics
GP102	Bharatnatyam
GP103	Chess
GP104	Drawing and Painting
GP105	Flute
GP106	Guitar
GP107	Harmonium
GP108	Photography
GP109	Tabla
GP110	Taekwondo
GP111	Vocal
GP112	Yoga and Pranayam
GP113	Ayurved
GP114	Constitution of India
GP115	Film Appreciation
GP116	Fundamentals of Banking
GP118	Homeopathy
GP119	Life Style management
GP120	Nutrition and Fitness
GP121	Shares and Stock